

Excellence in door opening + closing solutions



KENWA

Auto Hinge™

Self Closing Door Hinge
(Center Hang Type)

Product Catalog



AUTO-HINGE Center Hang Type

A series



AFD-M series



**Concealed door hinge with self-closing function.
Built into the door, offering clean exterior appearance.**

AUTO-HINGE

Center Hang Type

- Concealed design, built into the bottom side of the door.
Completely hidden inside the door, offering streamlined door appearance.
- Suitable not only for regular swing doors, but also for fire doors, smoke ventilations or air intake doors.

A series and AFD-M series

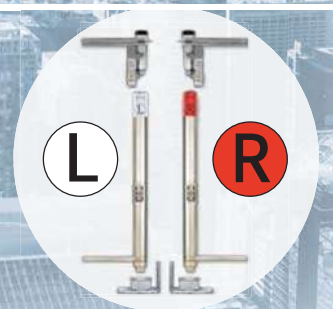

**Excellent performance and durability,
suitable for regular swing doors and/or fire doors.**

Fire doors



Contents

	Page
• Table of models with specifications	3
• Chart of applicable doors	3
• Top Pivot operation guide	4
(Double Shaft Top Pivot / Screw Top Pivot)	
• A series (External dimensions and fitting diagrams)	5 - 12
• AFD-M series (External dimensions and fitting diagrams)	13 - 26
• Installation precautions	27
• Roll-in system (A(AFD)-8KH-40A) :	
Door hanging and spring winding procedures	28
• Closing speed adjustment	28
• Decorative Rubber Plate	29
• Recommended cutout dimensions for the spring-winding window (for respective door thickness)	29
• Fixed Receptive Base	30

Center Hang Type

Designed with abundant experience and advanced technology.

Adopted for the public telephone booths in Japan

The product has been adopted by Nippon Telegraph and Telephone Corp. (NTT), Japan's largest communication company, for their public telephone booths throughout Japan. The outstanding performance and durability (500,000 or more of closing operations) have been recognized among millions of users all over the world.

Concealed type (door built-in type)

Pivot-hanging/built-in type door closer, easy to install. Being concealed into the door, offers beautiful and clean streamline door appearance.

Wide range of use

Slim size receptive base is compatible with thinner floor slabs in the late modern buildings, can be installed without damaging floor surfaces. Suitable in the place where the floor hinge is hardly installed or the door closer arm becomes obstacle.

Suitable for fire doors, smoke ventilations, air intake doors or regular swing doors.

Combining with electromagnetic release mechanism, automatically close the fire doors or opens the smoke ventilations/air intake doors as interlocking with smoke sensors.

Decorative rubber plate

Supplied with decorative rubber plates for screening the speed control/spring-winding windows.

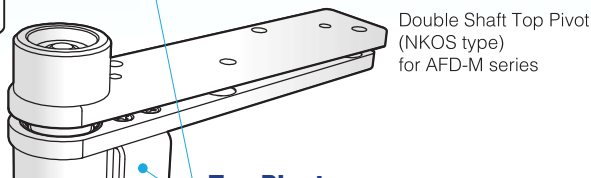
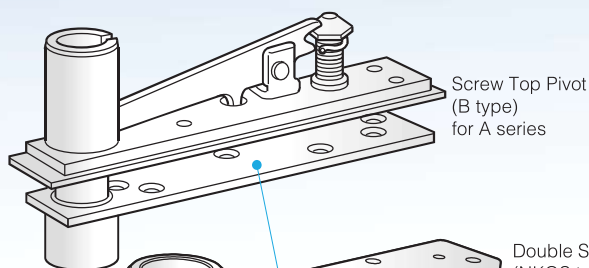

Top Pivot

- B type can be installed reversely.
- Options are available for special applications (such as Electrified Top Pivot N-22BT/N-23BT).

Easy closing speed adjustment

- Easy to adjust the closing speed in a wide range, simply by turning the speed control gear clockwise or anticlockwise.

Smooth closing

- Optimum door closing operation is achieved by employing unique hydraulic control mechanism. Door closes quite smoothly and quietly.

Free closing force adjustment

- Easy to adjust the door closing force freely by winding up/down the spring.

Powerful closing force

- Each model offers optimum closing force so that realizes safe and secure closure/latching motion for different size of doors. Also special square wire spring has been employed to achieve high performance and durability.

Easy installation, saving cost.

- Very thin, yet robust, fixed base plate makes installation easy and fast and saves cost of labor.

Sliding receptive base

- Can be installed within minimal cavity on the floor.
- With a slide-in design, it is easy to set and align the door into the receptive base during installation.

Stop mechanism
None



Table of models with specifications

Center Hang Type

Mode		Door size applicable (mm)			Door weight (kg)	Standard closing force (N·m)	Spring set system	Max, opening angle	Top Pivot		Page	
A series	AFD-M series	W	H	D					A series	AFD-M series	A series	AFD-M series
A-8KH	AFD-8KH-M	800 (max.)	2000 (max.)	36 (min.)	50 (max.)	6.9	Roll-in system	180° right or left one-side opening	N-21B	NKOS-M18	5	13
A-12H	AFD-12H-M	1200	2100	40	100	15.7					6	15
A-14H	AFD-14H-M	1400			130	19.7					7	17
A-16H	AFD-16H-M	1600	2400	45	160	24.6			8	19		
A-22	AFD-22-M	2200			50	49.1			9	21		
A-30	AFD-30-M	3000	2600	55	410	68.7			N-23B	NKOS-M20	10	23
A-35A	AFD-35A-M	3500			650	73.6			11	25		
A-40A	—	4000	3000	65	1000	78.5			N-25B	-	12	-

Note:

- The opening directions are shown by the symbols suffixed at the end of model No. ; "R" for right-hand open and "L" for left-hand open.
- Pre-set type can be used as roll-in system by unwinding the spring.
- One(1) set consists of main hinge, receptive base, Top Pivot and Decorative Rubber Plates.
- Stop mechanism is not applicable.
- Select suitable model by referring to [Chart for Applicable Doors] shown below.
- Fixed type (floor type) receptive base is available as option for a place to which the sliding receptive base is not applicable.
- The models from A-8KH/AFD-8KH-M to A-16H/AFD-16H-M have a spring winding-window on both sides of hinge main body.

Model No. system

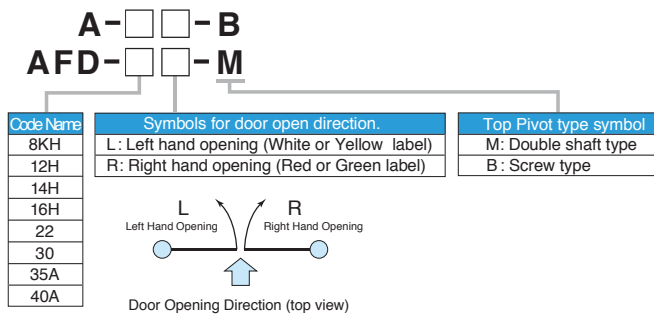

Top pivot

For AFD-M series

Double shaft type
NKOS-M□□



For A series

Screw type
N-□□B



Chart of applicable doors

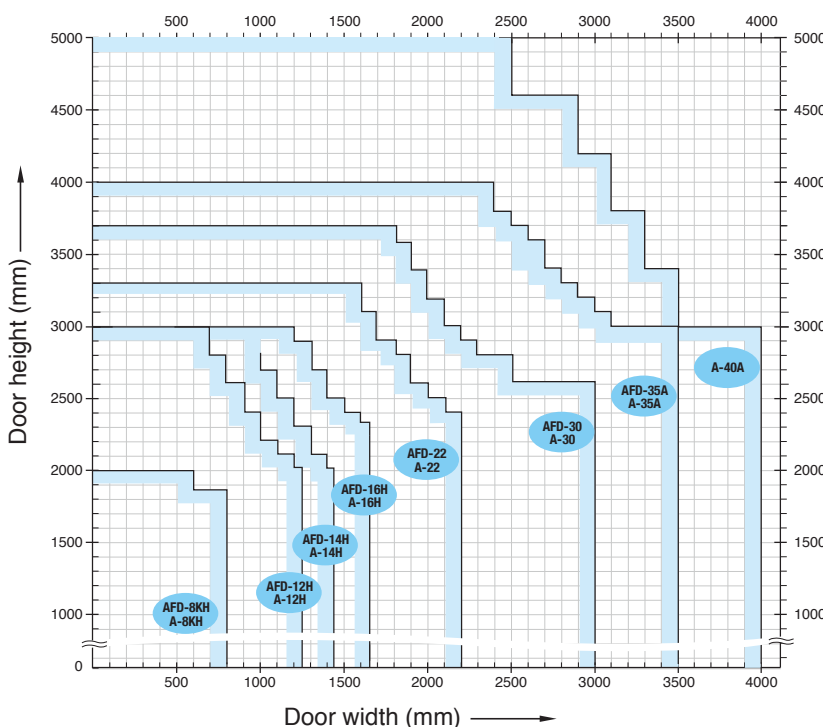

- Select an appropriate model according to the dimensions (height x width) of the door used. (See the chart on left.)
- Make sure that the door weight is within the range of [Table of Applicable Door Weight] (below) and determine the model.

Note:

Based on the condition that wind velocity of 3 m/sec is applied.

Contact us when using on a forced smoke ventilation or at the place with strong wind.

Table of applicable door weight

Model	Weight/1m ²	Type of doors
A-8KH AFD-8KH	31 kg/m ² max.	Steel door (only for wicket door)
A-12H AFD-12H	39 kg/m ² max.	Steel door
A-14H AFD-14H	41 kg/m ² max.	
A-16H AFD-16H		
A-22 AFD-22	45 kg/m ² max.	
A-30 AFD-30	52 kg/m ² max.	
A-35A AFD-35A	61 kg/m ² max.	
A-40A	83 kg/m ² max.	

1. Shaft preset (lowering)

To hang the door, turn the preset screw (upper screw) of the Top Pivot to the direction of arrow (direction of door hanging side) and lower the shaft. The inner and outer shafts are simultaneously lowered and set. Turn the preset screws until you hear a click sound. Make sure the shaft is completely lowered down.

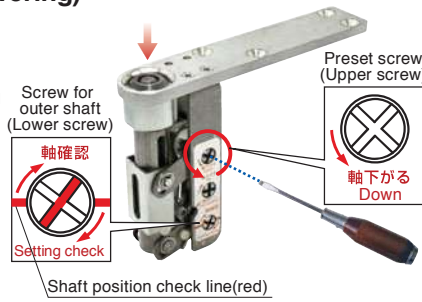

2. Shaft set (lifting)

Align the axes of the frame side pivot bearing and the door side pivot and turn the set screw (middle screw) to the direction of the arrow (to the direction of the door front end). Then the inner shaft and the outer shaft will pop out and get set into the bearings of the frame side pivot. After the door is installed, make sure that the red line of shaft setting screw (lower screw) is aligned with the shaft position check line (outer red line).

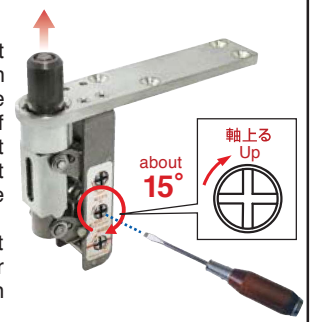

3. Confirm shaft insertion

After completing "2. Shaft set (lifting)", carefully check below; After the door is installed, make sure that the red slot line on the shaft setting screw (lower screw) is aligned with the shaft position check line (outer red line). Also make sure that the green shaft checking pin (ø5 mm) appears in the shaft window.

[Confirm shaft insertion]

If the red slot line on the shaft setting screw is not aligned with the shaft position check line (outer red line) and you cannot see the shaft setting check pin through the shaft operation window, the shaft is not seated in the hole properly and may cause the door fall off.

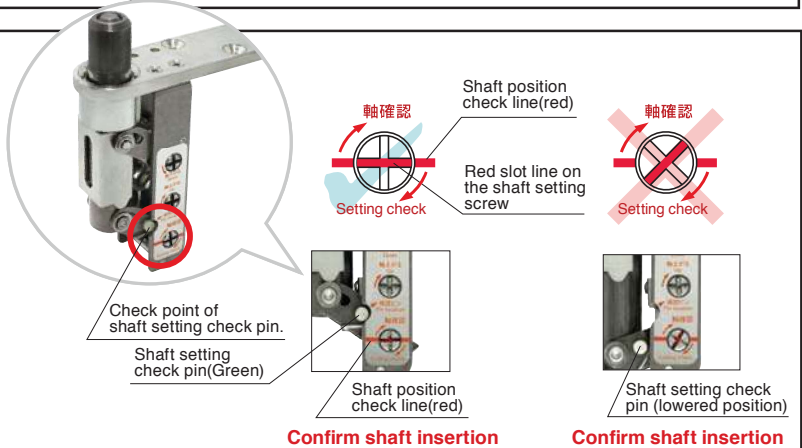

To Remove Door

To remove the door, turn the shaft releasing screw (upper screw) towards the direction of the arrow (direction of door hanging side) as same manner as 1. "Shaft preset (lowering)". The outer/inner shafts will come down and be disengaged from the frame side bearing.

Precautions

1. Do not use the product in the place exposed to rain/water.
2. Use the product only with suitable door size, weight, material and location as specified in this catalog.
3. Make sure that the mounting screws for the top pivot are securely fastened.
4. Periodically check the condition of product (at least once a year) and make sure that the product is properly installed.
5. Do NOT weld the Top Pivot.
6. Make sure that the red slot line on the shaft setting screw (lower screw) is aligned with the shaft position check line (outer red line).
7. Do not install the Top Pivot before the door/frame construction is completed. Do not carry out any hot works on the door/frame after the Top Pivot and Auto-Hinge are installed.
8. Make sure that the shaft is lowered when putting in/taking off the door.

Double Shaft Top Pivot - Operation:

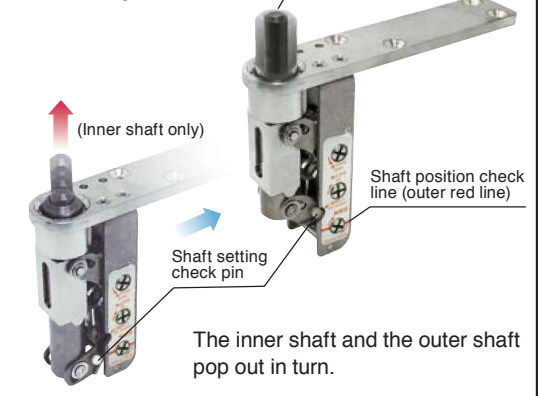

Screw Top Pivot (B type)

Operation guide

- Tighten the shaft height adjusting screw until the shaft is recessed from the surface of decorative plate. Insert the shaft fully into the door side bearing.
- Make sure that the middle tip of the lever plate comes out of the pivot checking hole.

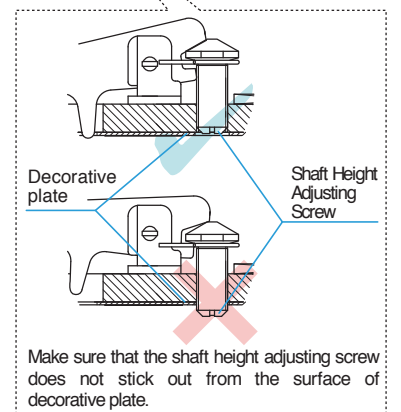
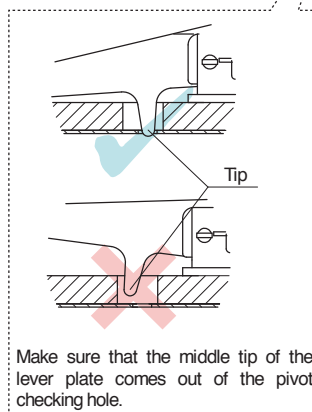
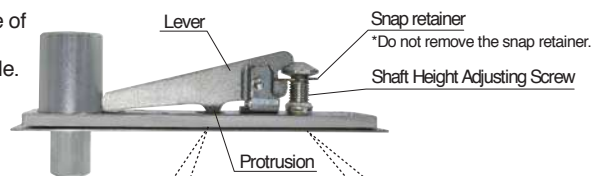
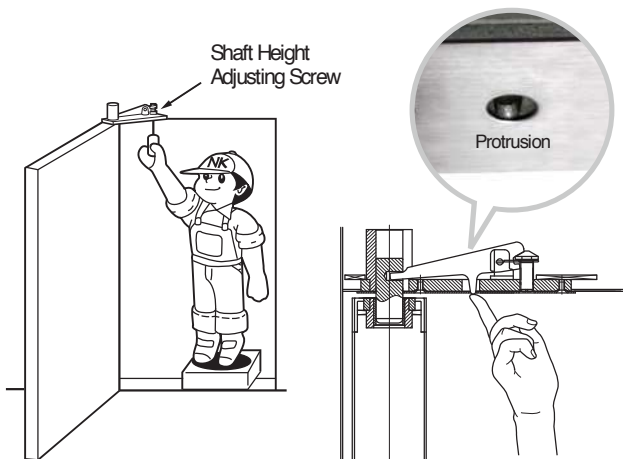

*Same for the reverse pivot installation. Make sure that the middle tip of the lever plate comes out properly.

Model		Door size applicable (mm)			Door weight (kg)	Closing force (N·m)	Spring set system	Max. opening angle	Indicating label
		W	H	D					
A-8KHR	Right-hand opening	800 max.	2000 max.	36 min.	50 max.	6.9	Roll-in system	180° right or left one-side opening	R : Green L : Yellow
A-8KHL	Left-hand opening								

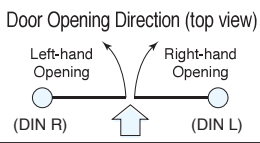

Top Pivot	Receptive Base
N-21B	U-2N

*This diagram shows the right-hand type.

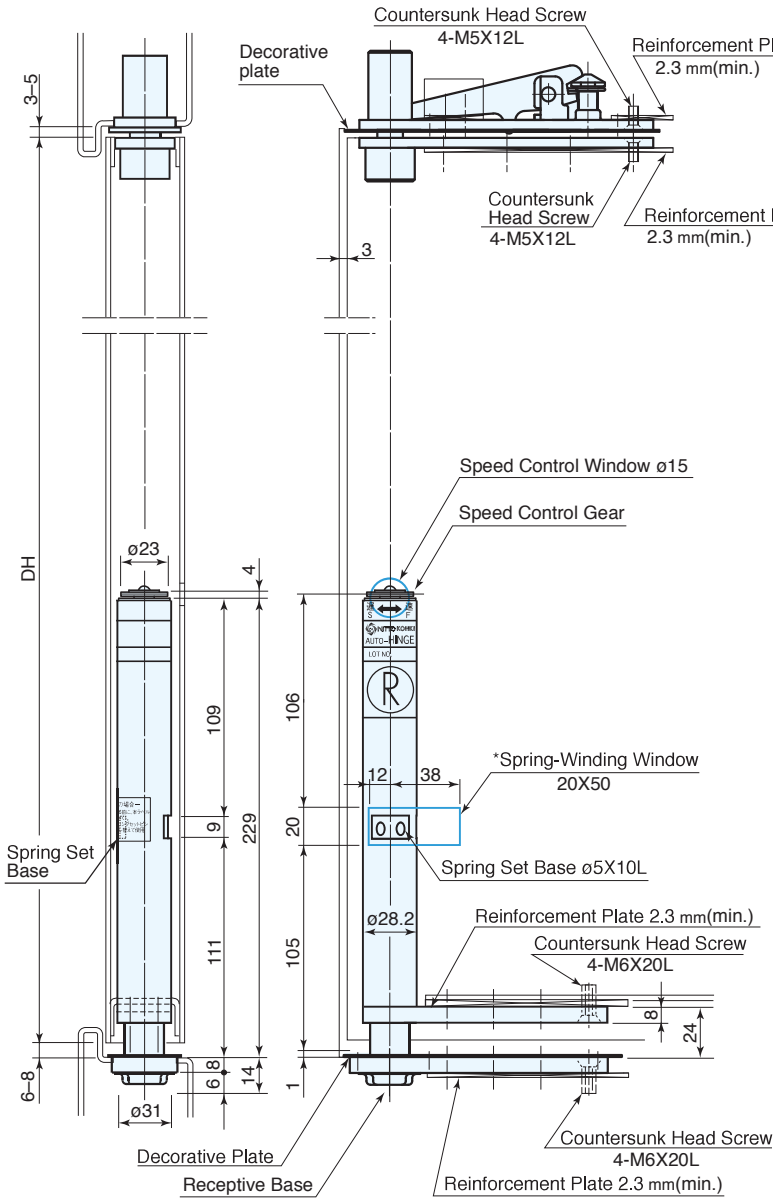

N-21B Top Pivot

The head shape of the adjusting screw is octagonal width across flat 17.

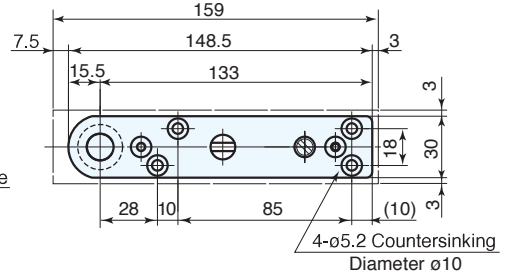

Upper Frame

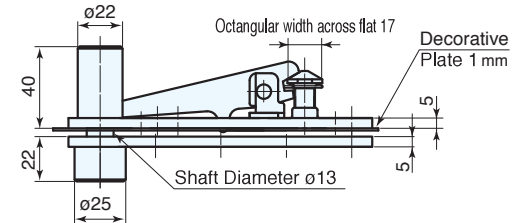

Door Side

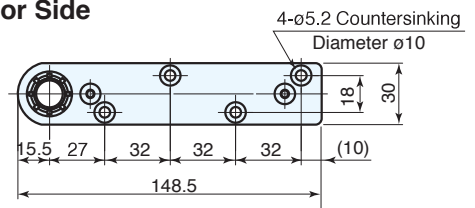

U-2N Receptive Base

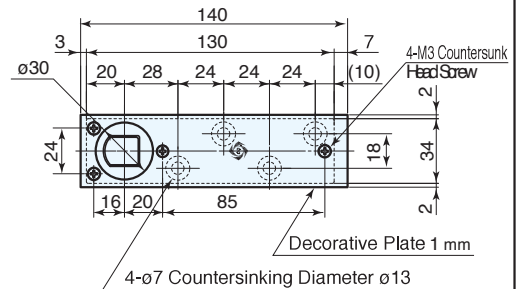

Spring Set Pin: 1 piece

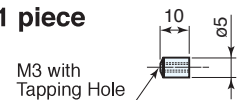

Mounting size of U-2N Receptive Base

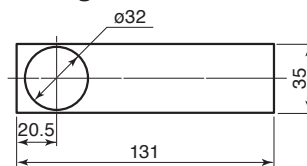

Unit: mm

In the case of 90° opening

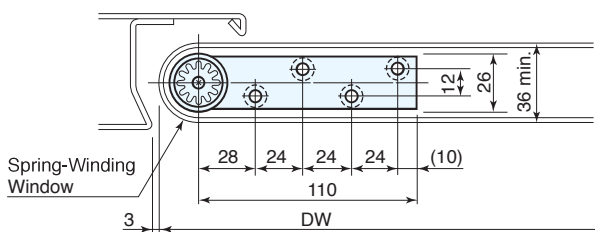

REMARKS

1. This diagram shows the installation example of right-hand opening doors. There is a spring winding-window on both sides of hinge main body.
2. To cover the door cutouts for speed control window and spring-winding window, use the decorative rubber plate supplied with the product. (See page 29)

Model		Door size applicable (mm)			Door weight (kg)	Closing force (N·m)	Spring set system	Max. opening angle	Indicating label
		W	H	D					
A-12HR	Right-hand opening	1200 max.	2100 max.	40 min.	100 max.	15.7	Roll-in system	180° right or left one-side opening	R : Green L : Yellow
A-12HL	Left-hand opening								

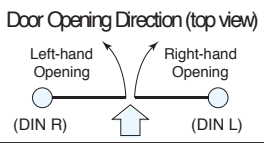

Door Opening Direction (top view)	Top Pivot	Receptive Base
Left-hand opening (DIN R)	N-21B	U-3SN

*This diagram shows the right-hand type.

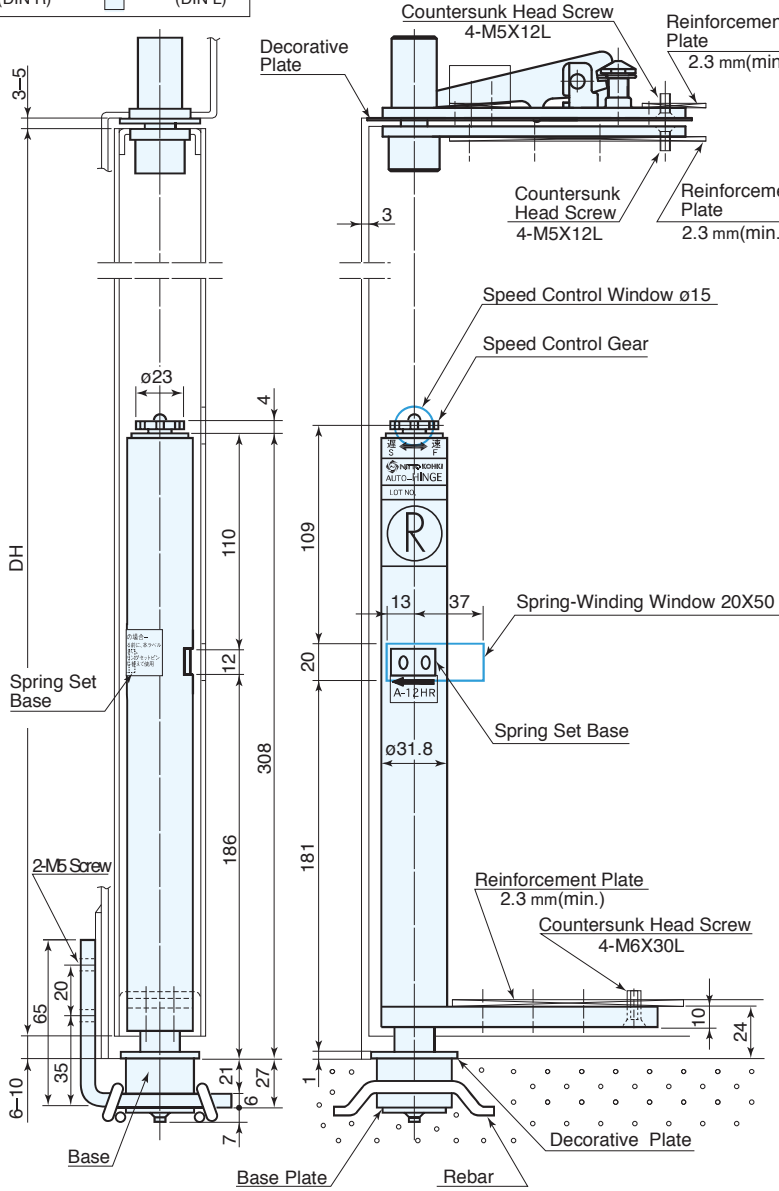

N-21B Top Pivot

The head shape of the adjusting screw is octagonal width across flat 17.

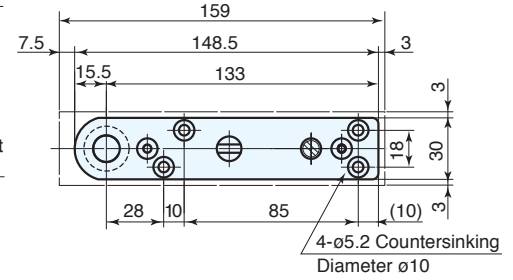

Upper Frame

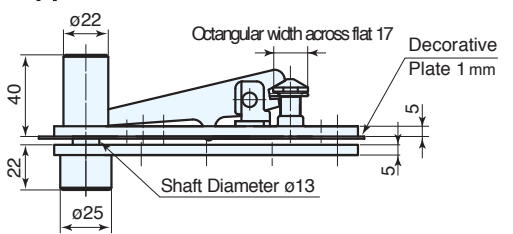

Door Side

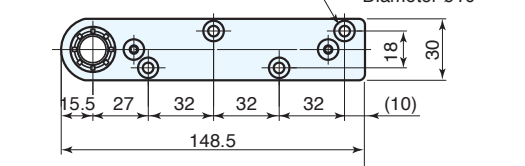

U-3SN Receptive Base

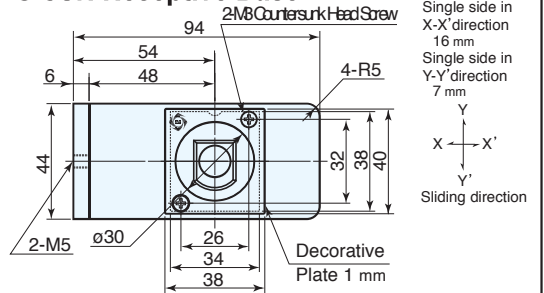

Spring Set Pin: 1 piece



In the case of 90° opening

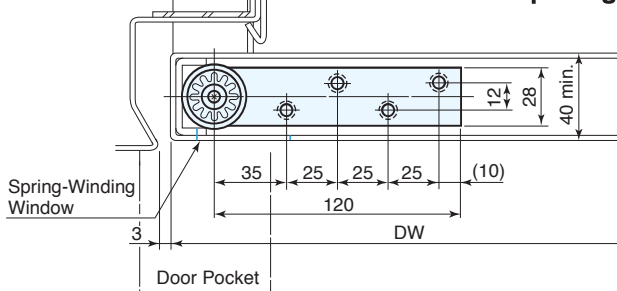

In the case of 180° opening

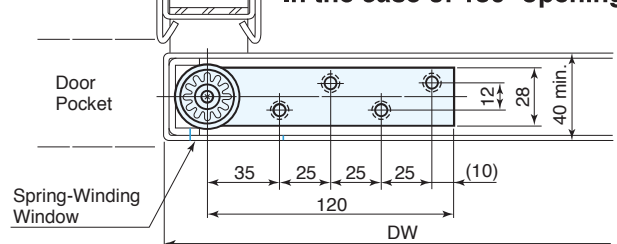

Unit: mm

REMARKS

1. This diagram shows the installation example of right-hand opening doors. There is a spring winding-window on both sides of hinge main body.
2. The receptive base must be adjusted and centered by using a plumb bob from the top pivot. The base must be firmly welded onto the base plate.
3. To cover the door cutouts for speed control window and spring-winding window, use the decorative rubber plate supplied with the product. (See page 29)

Model		Door size applicable (mm)			Door weight (kg)	Closing force (N·m)	Spring set system	Max. opening angle	Indicating label
		W	H	D					
A-14HR	Right-hand opening	1400 max.	2100 max.	40 min.	130 max.	19.7	Roll-in system	180° right or left one-side opening	R : Green L : Yellow
A-14HL	Left-hand opening								

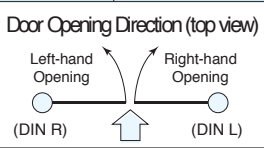

Door Opening Direction (top view)	Top Pivot	Receptive Base
	N-21B	U-3SN

*This diagram shows the right-hand type.

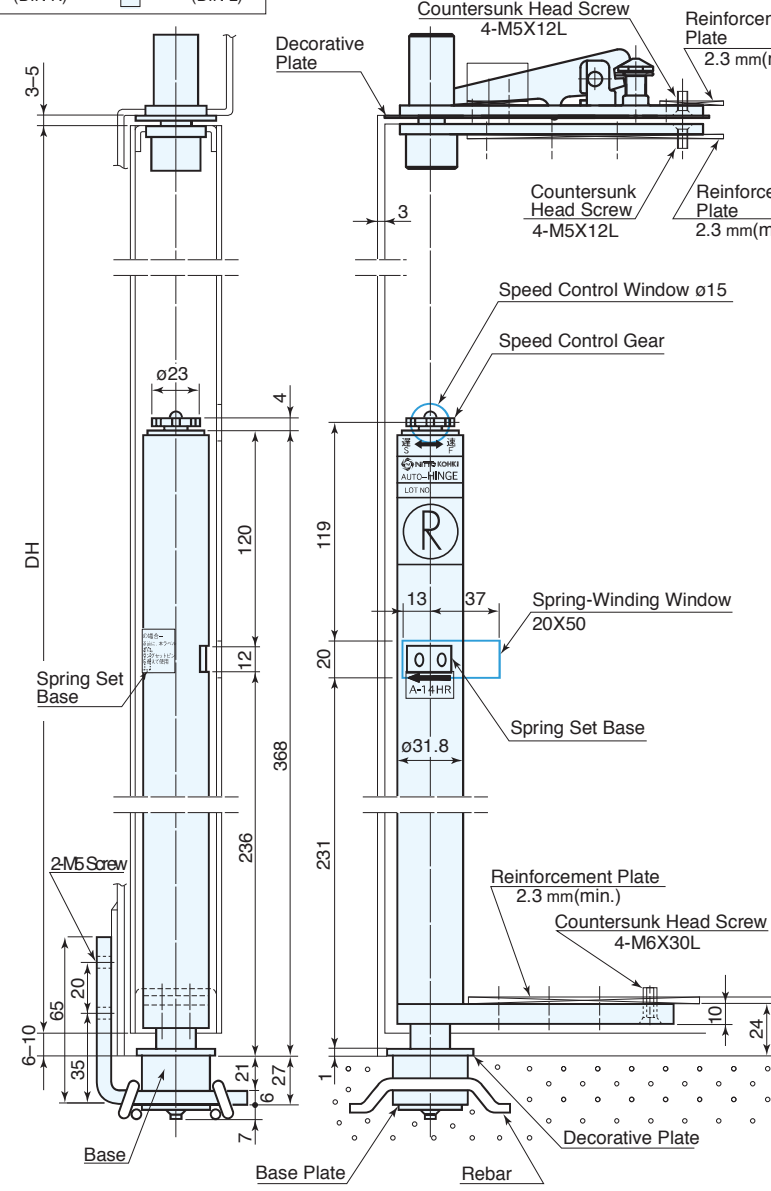

N-21B Top Pivot

The head shape of the adjusting screw is octagonal width across flat 17.

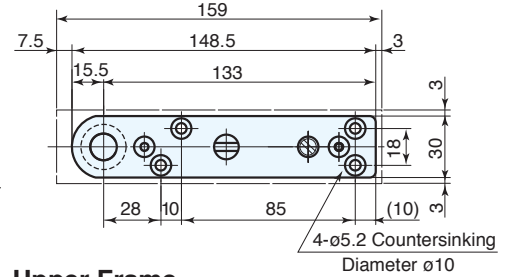

Upper Frame

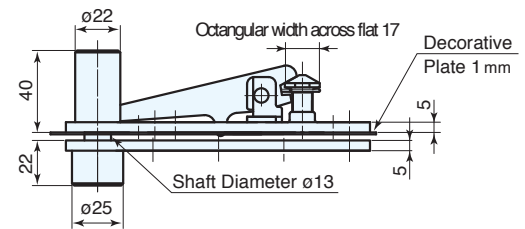

Door Side

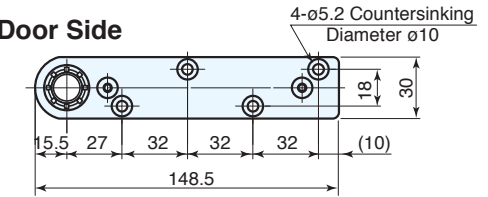

U-3SN Receptive Base

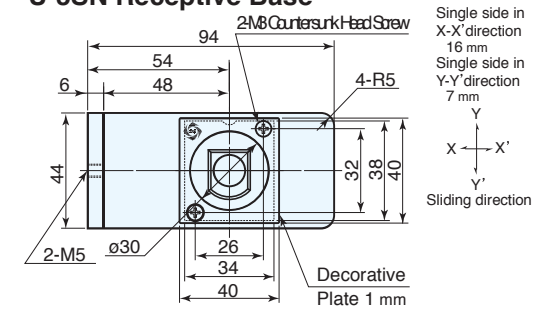

Spring Set Pin: 1 piece



In the case of 90° opening

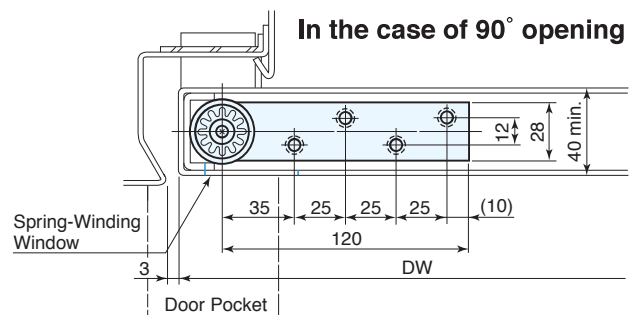

In the case of 180° opening

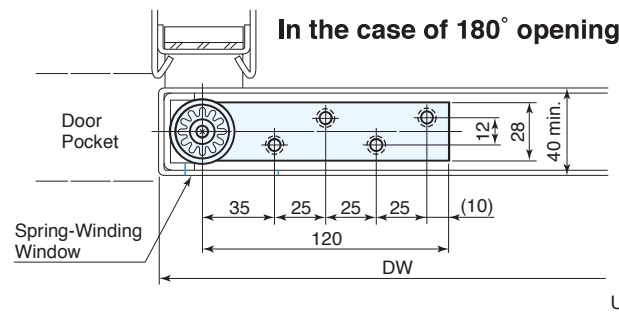

Unit: mm

REMARKS

- This diagram shows the installation example of right-hand opening doors. There is a spring winding-window on both sides of hinge main body.
- The receptive base must be adjusted and centered by using a plumb bob from the top pivot. The base must be firmly welded onto the base plate.
- To cover the door cutouts for speed control window and spring-winding window, use the decorative rubber plate supplied with the product. (See page 29)

Model		Door size applicable (mm)			Door weight (kg)	Closing force (N·m)	Spring set system	Max. opening angle	Indicating label
		W	H	D					
A-16HR	Right-hand opening	1600 max.	2400 max.	45 min.	160 max.	24.6	Roll-in system	180° right or left one-side opening	R : Green L : Yellow
A-16HL	Left-hand opening								

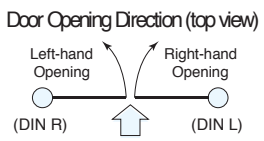

Top Pivot	Receptive Base
N-22B	U-3SN

*This diagram shows the right-hand type.

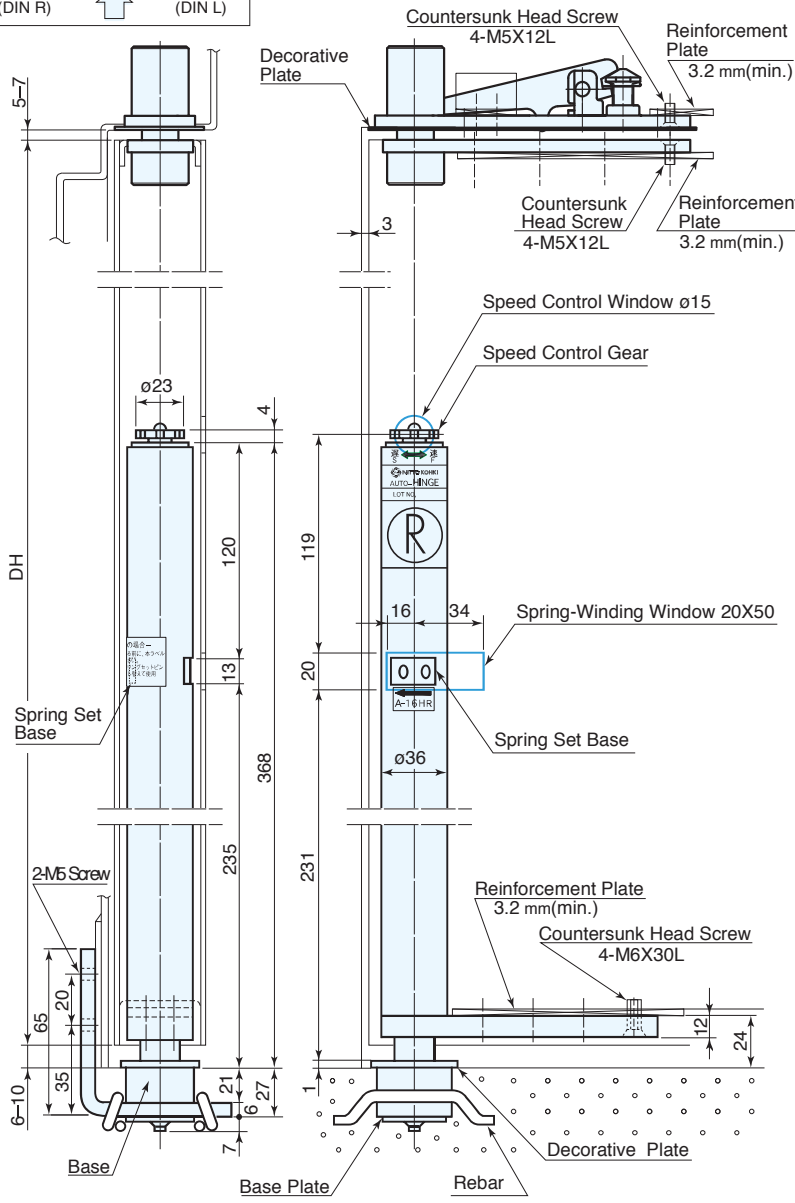

N-22B Top Pivot

The head shape of the adjusting screw is octagonal width across flat 17.

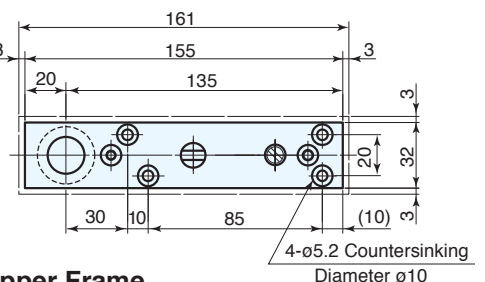

Upper Frame

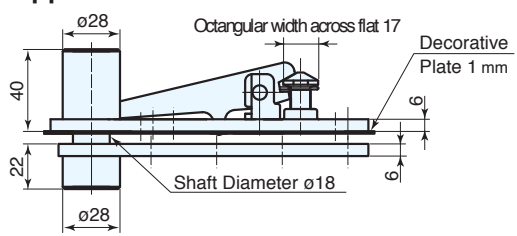

Door Side

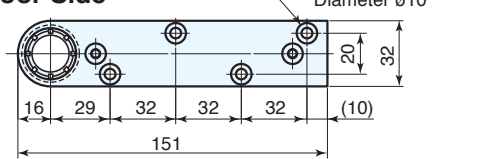

U-3SN Receptive Base

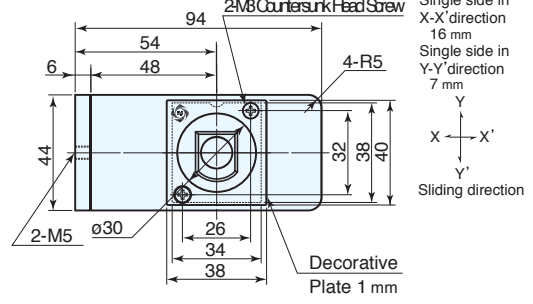

Spring Set Pin: 1 piece

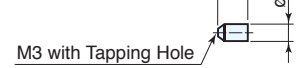

In the case of 90° opening

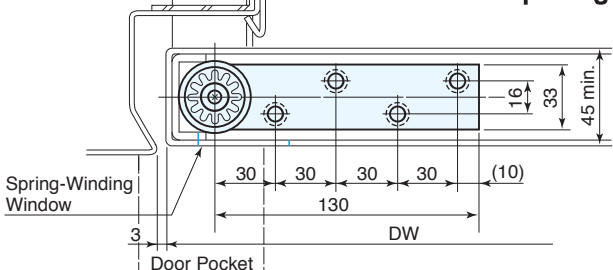

In the case of 180° opening

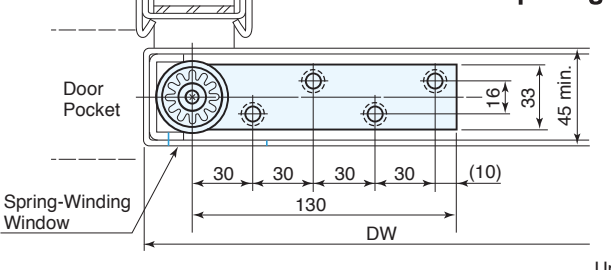

Unit: mm

REMARKS

1. This diagram shows the installation example of right-hand opening doors. There is a spring winding-window on both sides of hinge main body.
2. The receptive base must be adjusted and centered by using a plumb bob from the top pivot. The base must be firmly welded onto the base plate.
3. To cover the door cutouts for speed control window and spring-winding window, use the decorative rubber plate supplied with the product. (See page 29)

Model		Door size applicable (mm)			Door weight (kg)	Closing force (N·m)	Spring set system	Max. opening angle	Indicating label
		W	H	D					
A-22R	Right-hand opening	2200 max.	2400 max.	50 min.	240 max.	49.1	Roll-in system	180° right or left one-side opening	R : Green L : Yellow
A-22L	Left-hand opening								

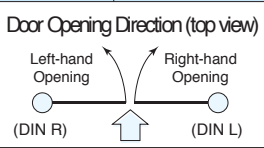

Top Pivot	Receptive Base
N-22B	U-6SN

*This diagram shows the right-hand type.

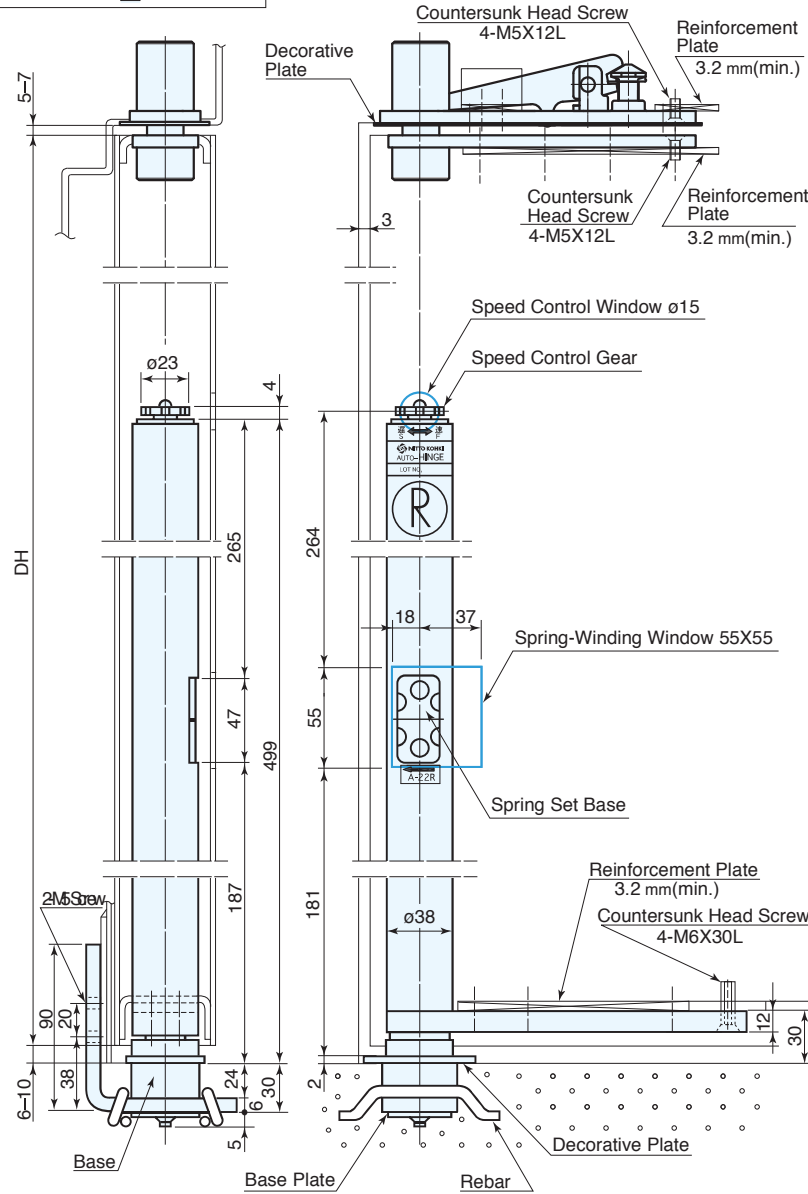

N-22B Top Pivot

The head shape of the adjusting screw is octagonal width across flat 17.

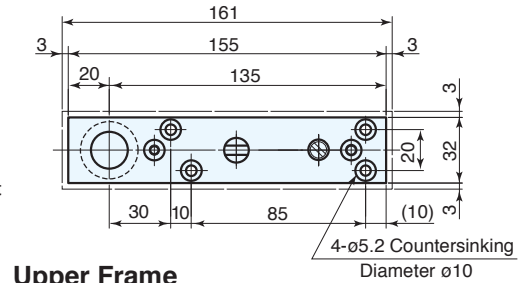

Upper Frame

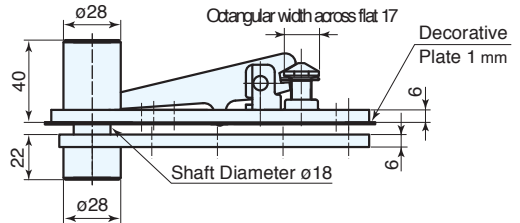

Door Side

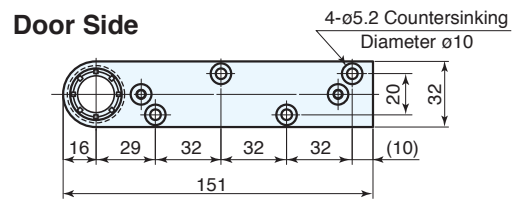

U-6SN Receptive Base

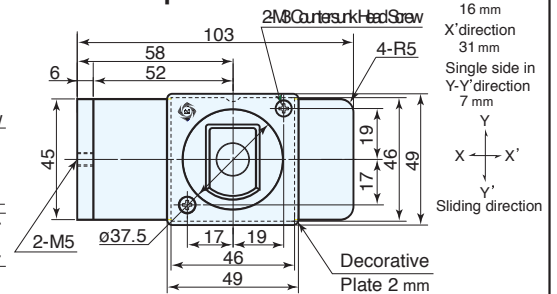

Spring Set Pin: 2 pieces

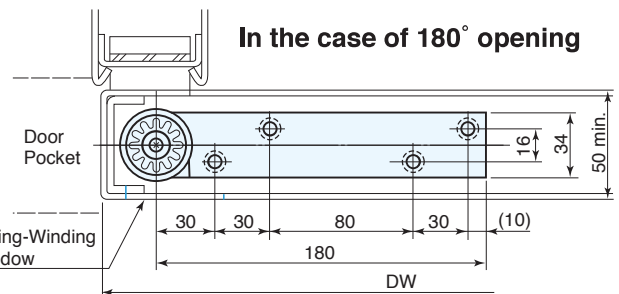
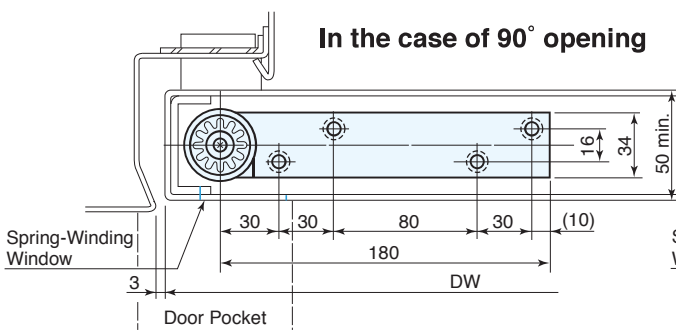
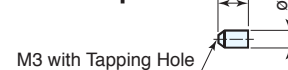

Unit: mm

REMARKS

1. This diagram shows the installation example of right-hand opening doors.
2. The receptive base must be adjusted and centered by using a plumb bob from the top pivot. The base must be firmly welded onto the base plate.
3. To cover the door cutouts for speed control window and spring-winding window, use the decorative rubber plate supplied with the product. (See page 29)

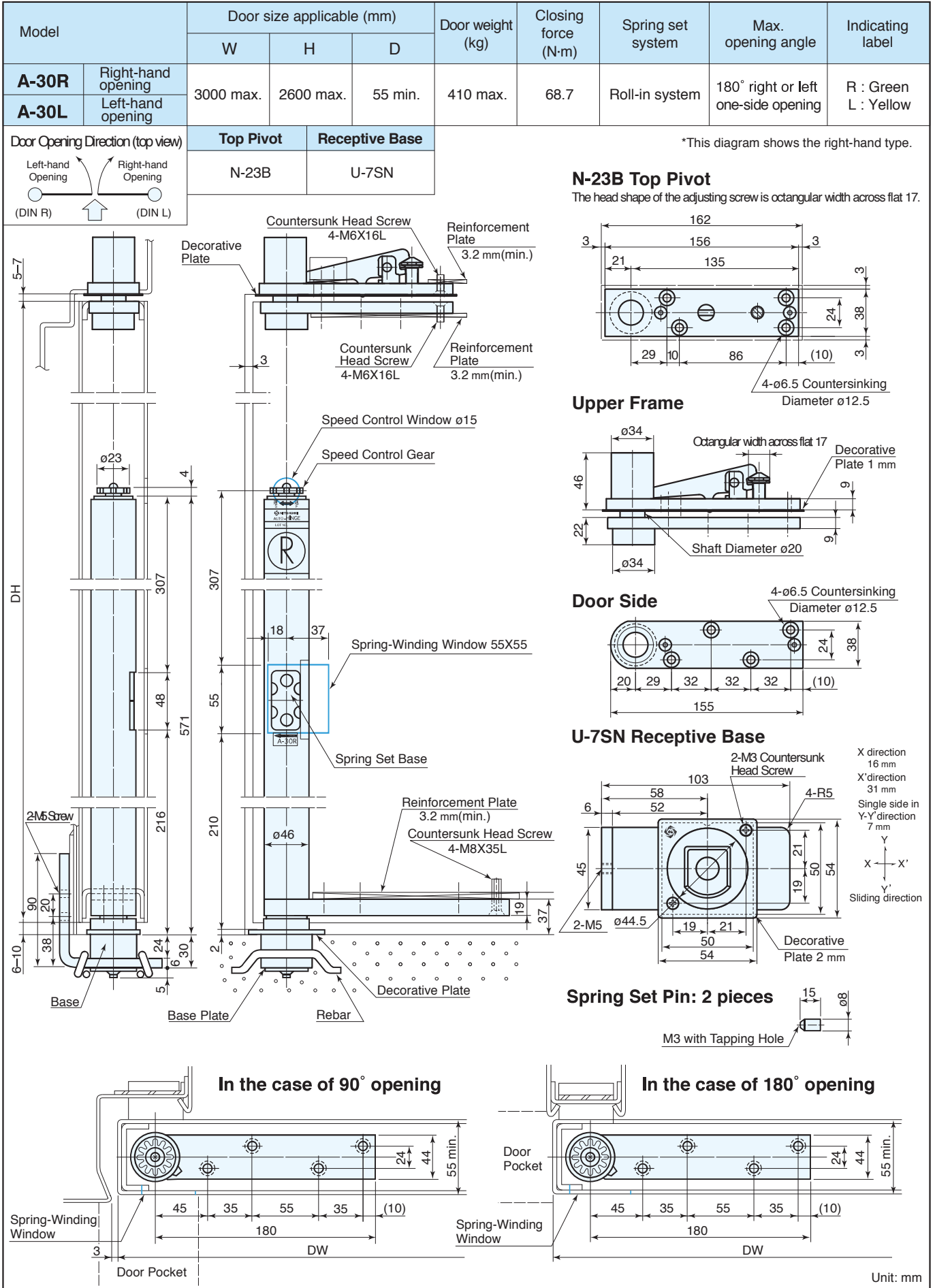

REMARKS

1. This diagram shows the installation example of right-hand opening doors.
2. The receptive base must be adjusted and centered by using a plumb bob from the top pivot. The base must be firmly welded onto the base plate.
3. To cover the door cutouts for speed control window and spring-winding window, use the decorative rubber plate supplied with the product. (See page 29)

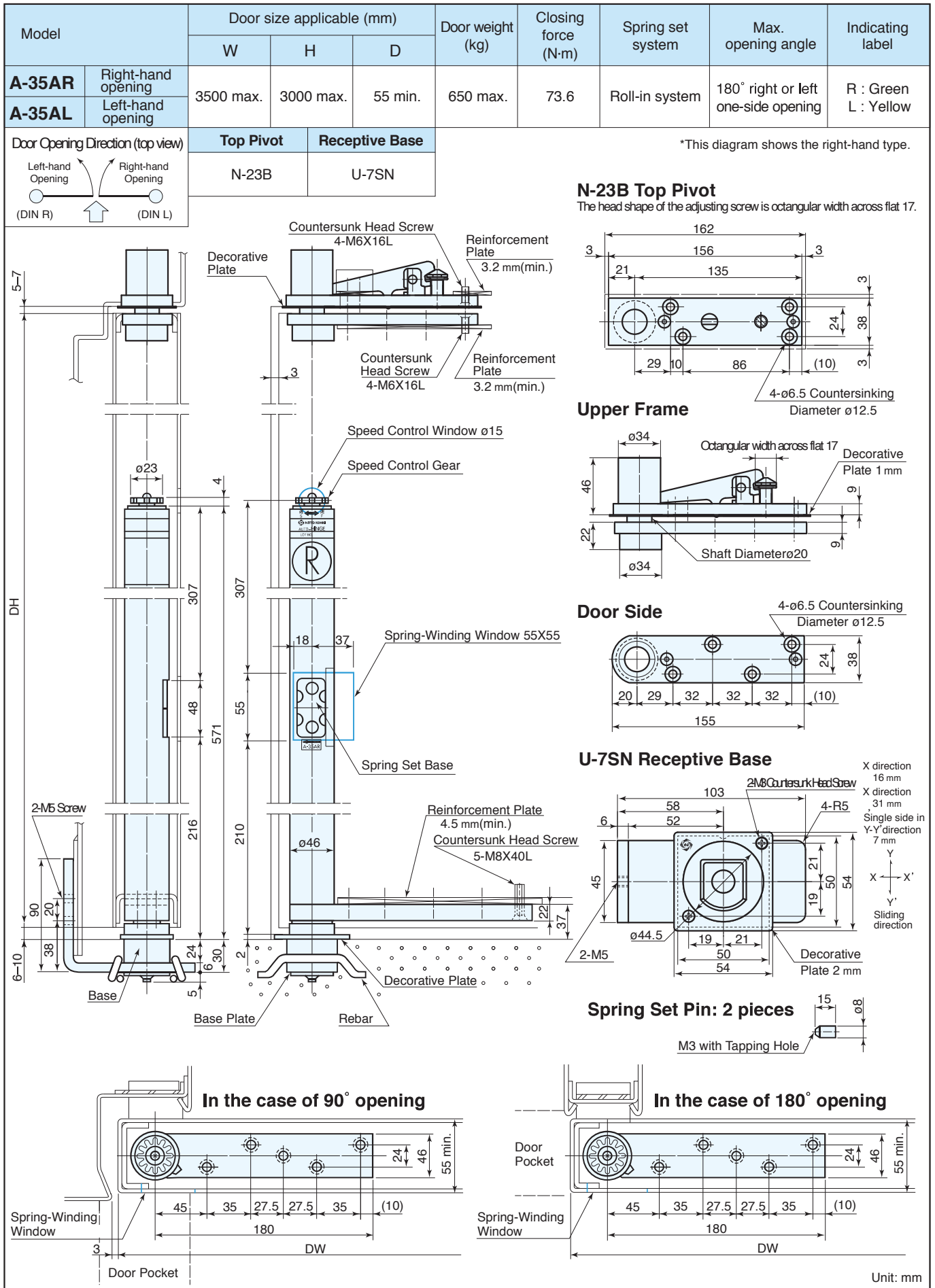

REMARKS

- This diagram shows the installation example of right-hand opening doors.
- The receptive base must be adjusted and centered by using a plumb bob from the top pivot. The base must be firmly welded onto the base plate.
- To cover the door cutouts for speed control window and spring-winding window, use the decorative rubber plate supplied with the product. (See page 29)

Model		Door size applicable (mm)			Door weight (kg)	Closing force (N·m)	Spring set system	Max. opening angle	Indicating label
		W	H	D					
A-40AR	Right-hand opening	4000 max.	3000 max.	65 min.	1000 max.	78.5	Roll-in system	180° right or left one-side opening	R : Green L : Yellow
A-40AL	Left-hand opening								

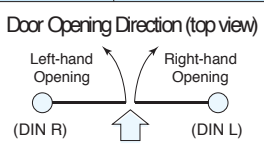

Top Pivot	Receptive Base
N-25B	U-7N

*This diagram shows the right-hand type.

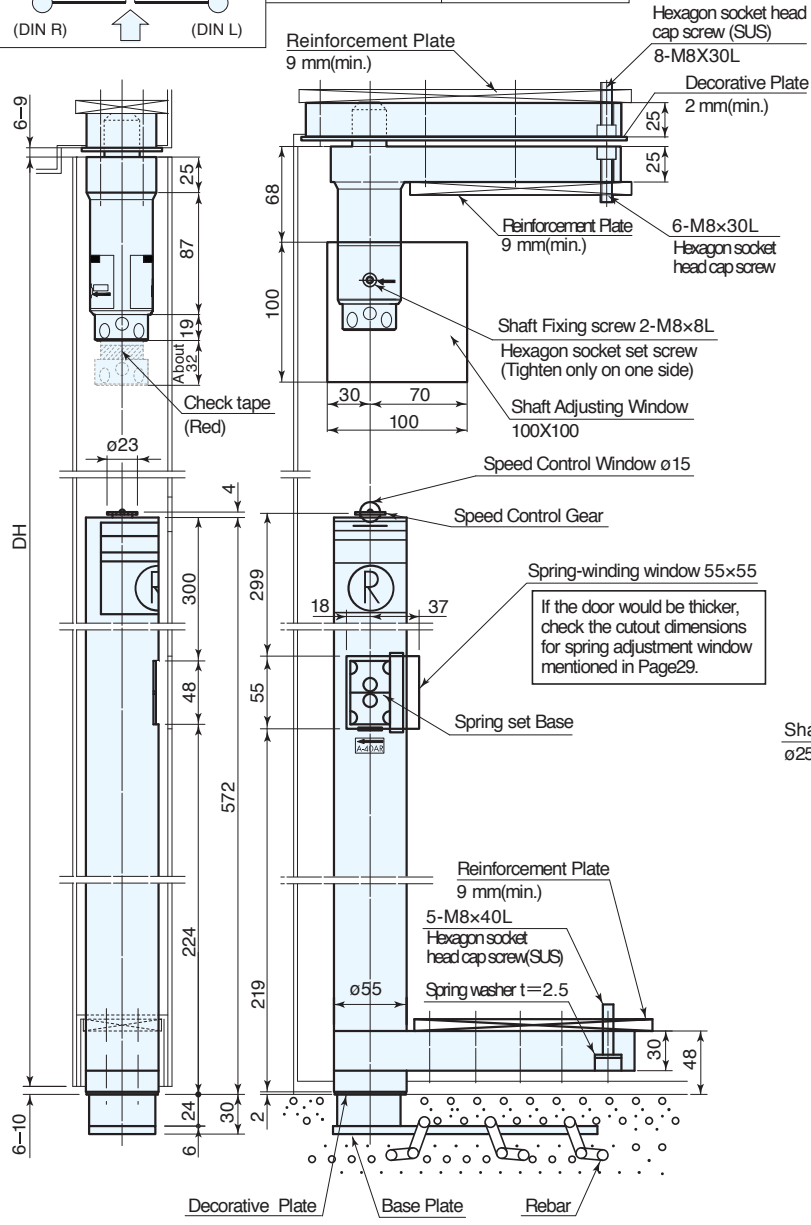

N-25B Top Pivot

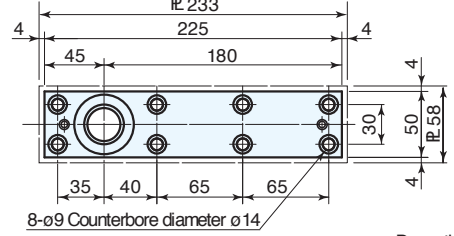

Upper Frame

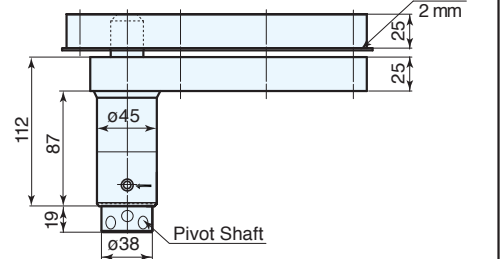

Door Side

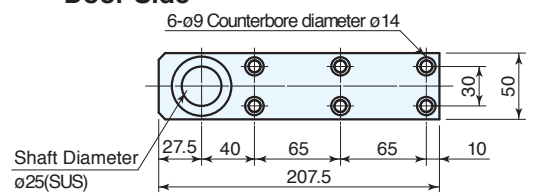

U-7N Fixed Receptive Base

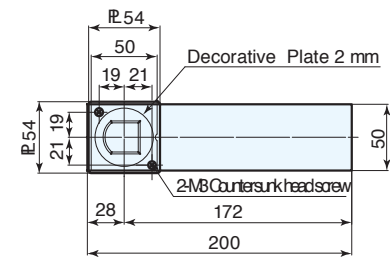

Spring Set Pin : 2 pieces

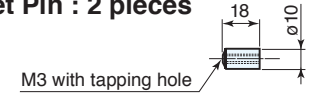

In the case of 90° opening

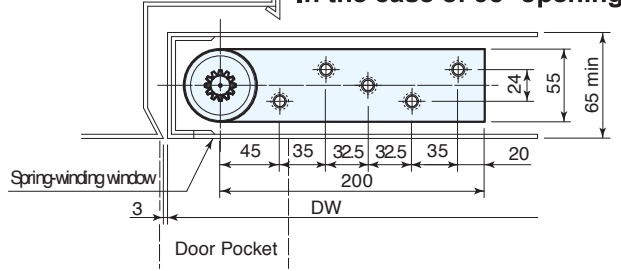

In the case of 180° opening

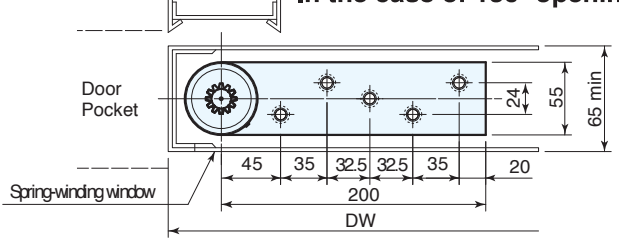

Unit: mm

REMARKS

1. This diagram shows the installation example of right-hand opening doors.
2. The receptive base must be adjusted and centered by using a plumb bob from the top pivot. The base must be firmly welded onto the base plate.
3. To cover the door cutouts for speed control window and spring-winding window, use the decorative rubber plate supplied with the product. (See page 29) Prepare a decorative cover for shaft fixing window of the top pivot.
4. Large force will be applied to each mounting point. Provide sufficient reinforcement.
5. Fix the top pivot securely as turning the shaft upward. Firmly tighten the shaft fixing screws.

Model	Door size applicable (mm)			Door weight (kg)	Closing force (N·m)	Spring set system	Max. opening angle	Indicating label
	W	H	D					
AFD-8KHR-M	800 max.	2000 max.	36 min.	50 max.	6.9	Roll-in system	180° right or left one-side opening	R : Red L : White
AFD-8KHL-M								

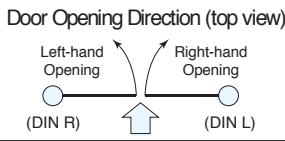

Top Pivot	Receptive Base
NKOS-M18	U-2N

*This diagram shows the right-hand type.

Double shaft type NKOS-M18 Top Pivot

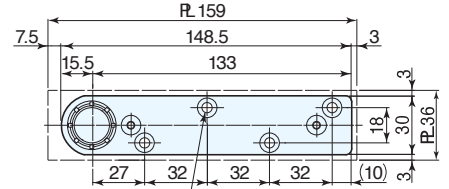

Upper Frame

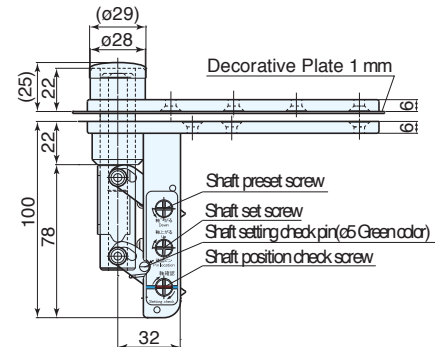

Door Side

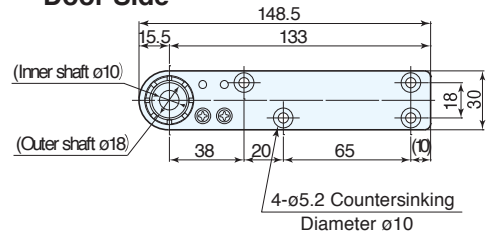

U-2N Receptive Base

*U-2N is compatible with all models from AFD-12H to 16H.

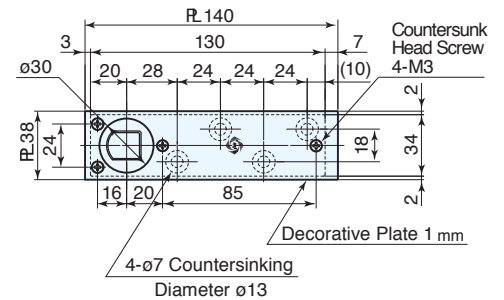

Spring Set Pin: 1 piece

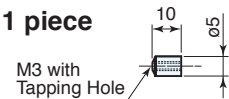

Mounting Size of U-2N Receptive Base

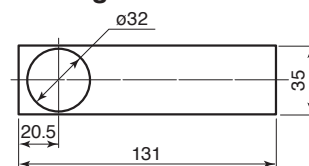

Unit: mm

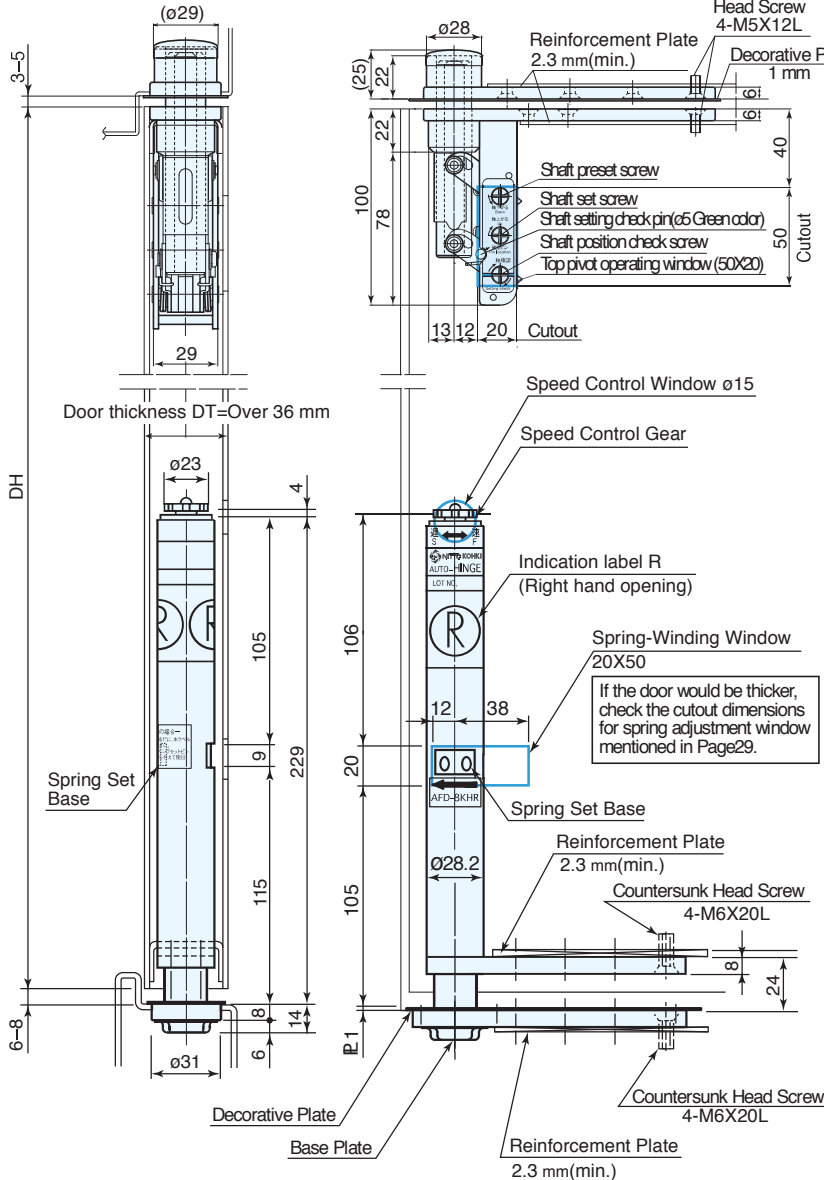

In the case of 90° opening

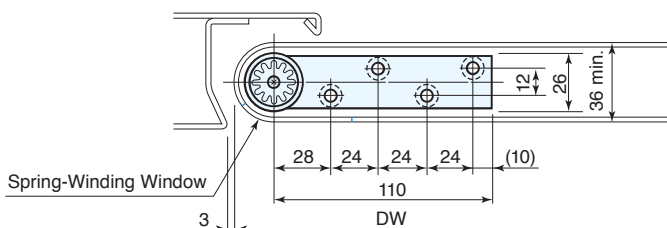

REMARKS

1. This diagram shows the installation example of right-hand opening doors. There is a spring winding-window on both sides of hinge main body.
2. To cover the door cutouts for speed control window and spring-winding window, use the decorative rubber plate supplied with the product. (See page 29)
3. When inserting the set pin into the set hole, use the set pin mounting screws (M3X50) supplied with the product.

Receptive Base (Option)

- Receptive Base for wicket door with no lower frame-
U-2F type

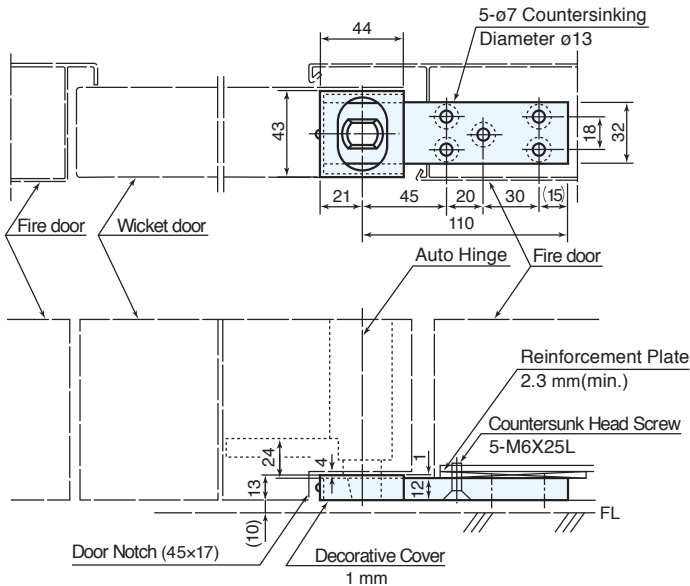

NU-3L type

*There is a different type suitable for the doors weighing 85 kg-130 kg.
(Type: NU-3LA, see page18.)

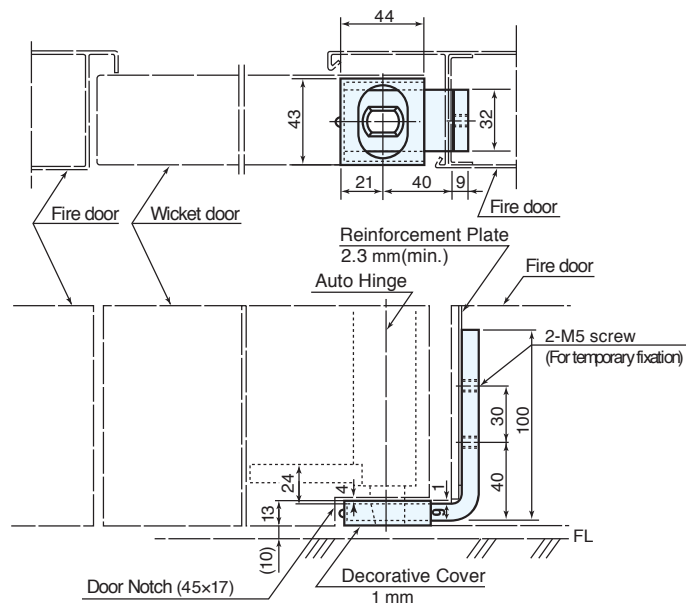

- ❶ This receptive base is suitable for the wicket door with no lower frame.
- ❷ Applicable wicket door size: 85 kg or less in weight, 40-45 mm in door thickness.
- ❸ Take off the decorative cover in case the door thickness is not much thick or the decorative cover is unnecessary.
- ❹ Use a reinforcement steel plate of at least 3.2 mm thick and 200 mm long.

Fixed Receptive Base
U-3N type

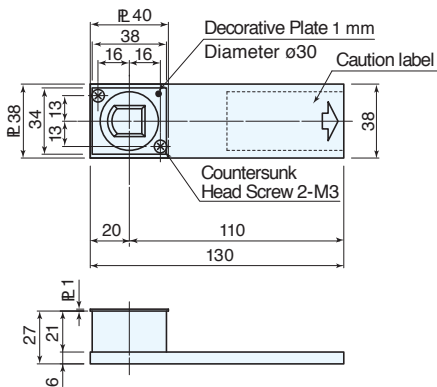

Slide Receptive Base
U-3SN type

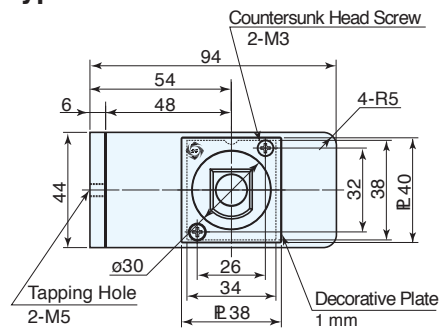

- Receptive Base for smoke ventilation-
U-2NH type

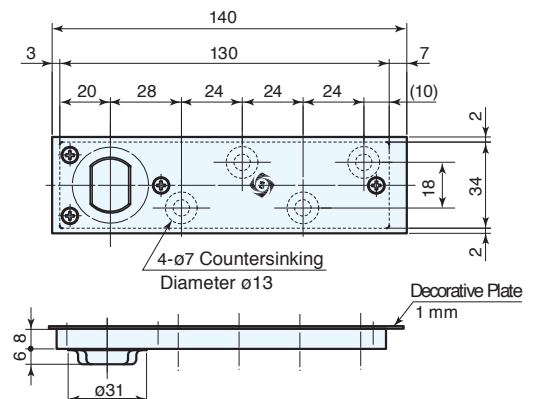
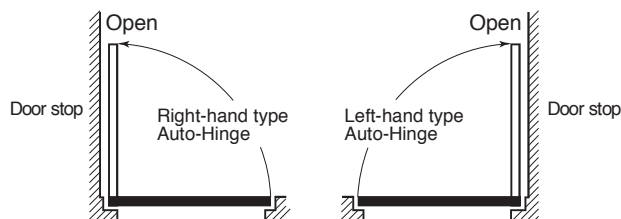

- When using for the smoke ventilations or air intake doors (automatic opening), use the Auto-Hinge left and right opposite. Also use the U-2NH receptive base.

Unit: mm

Model	Door size applicable (mm)	Door weight (kg)	Closing force (N·m)	Spring set system	Max. opening angle	Indicating label			
							W	H	D
AFD-12HR-M	Right-hand opening	1200 max.	2100 max.	40 min.	100 max.	15.7	Roll-in system	180° right or left one-side opening	R : Red L : White
AFD-12HL-M	Left-hand opening								

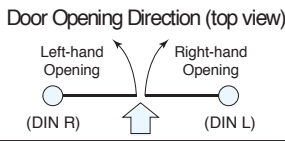

Top Pivot	Receptive Base
NKOS-M18	U-3SN

*This diagram shows the right-hand type.

Double shaft type NKOS-M18 Top Pivot

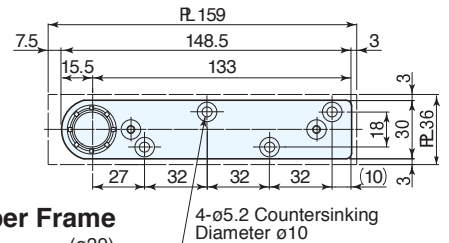

Upper Frame

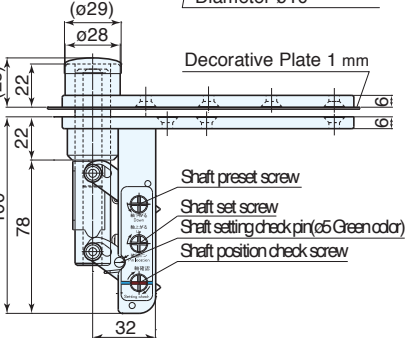

Door Side

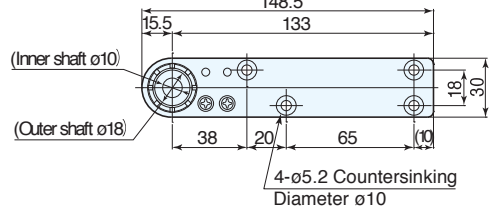

U-3SN Receptive Base

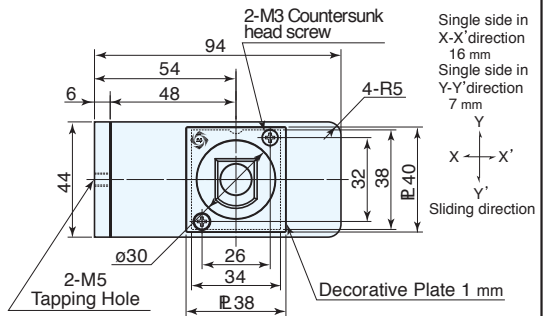

Spring Set Pin: 1 piece

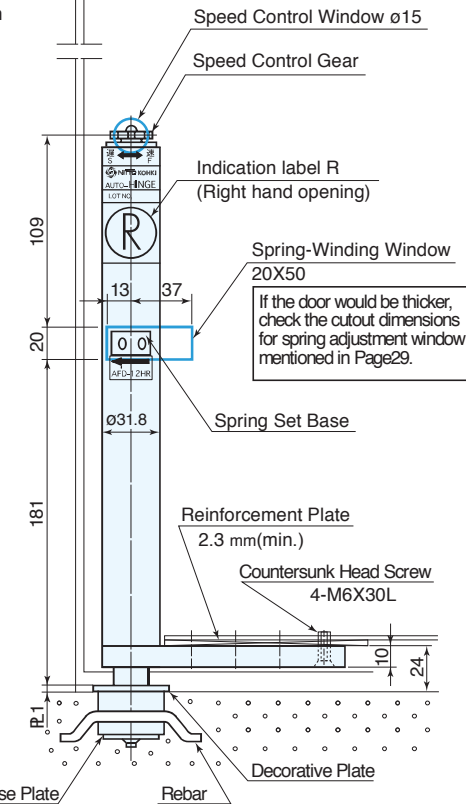
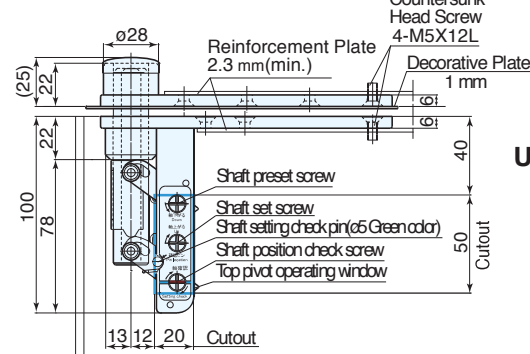
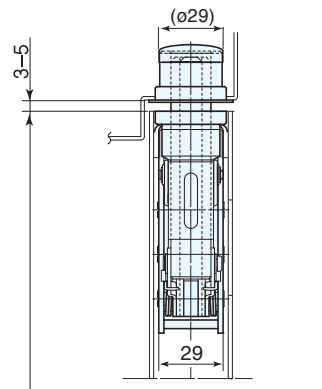

If the door would be thicker, check the cutout dimensions for spring adjustment window mentioned in Page 29.

In the case of 90° opening

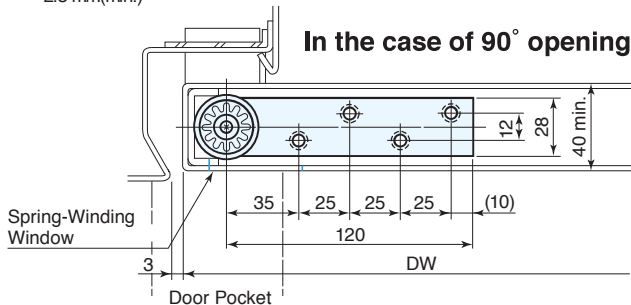

In the case of 180° opening

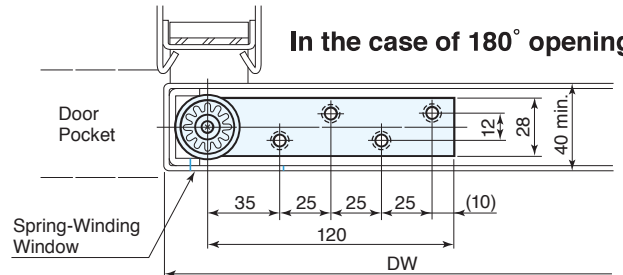

Unit: mm

REMARKS

1. This diagram shows the installation example of right-hand opening doors. There is a spring winding-window on both sides of hinge main body.
2. To cover the door cutouts for speed control window and spring-winding window, use the decorative rubber plate supplied with the product. (See page 29)
3. The receptive base must be adjusted and centered by using a plumb bob from the top pivot. The base must be firmly welded onto the base plate.
4. When inserting the set pin into the set hole, use the set pin mounting screws (M3X50) supplied with the product.

Receptive Base (Option)

- Receptive Base for wicket door with no lower frame-
U-2F type

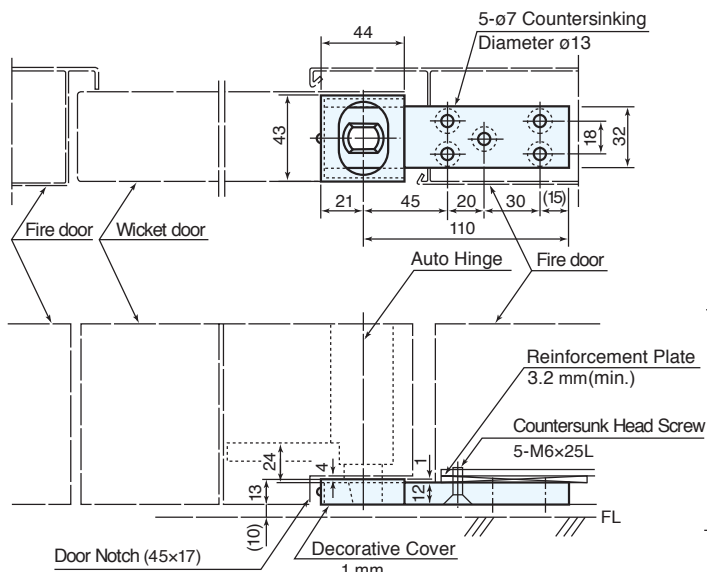

NU-3L type

*There is a different type suitable for the doors weighing 85 kg-130 kg.
(Type: NU-3LA, see page18.)

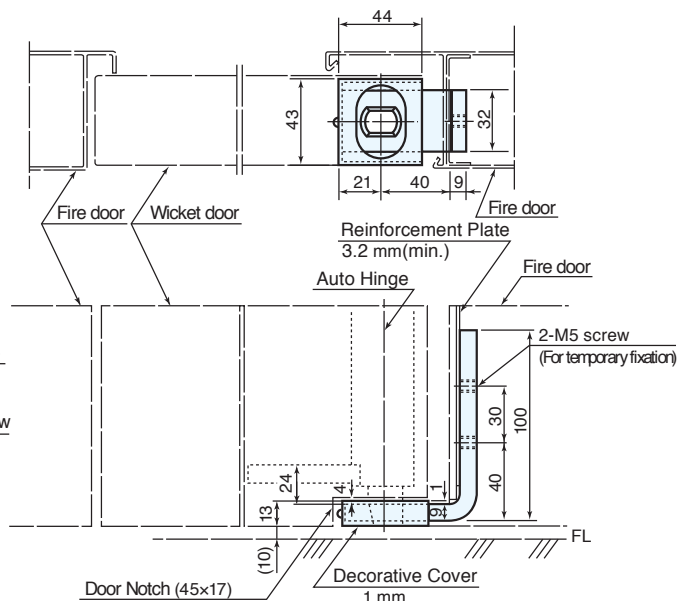

- ❶ This receptive base is suitable for the wicket door with no lower frame.
- ❷ Applicable wicket door size: 85 kg or less in weight, 40-45 mm in door thickness.
- ❸ Take off the decorative cover in case the door thickness is not much thick or the decorative cover is unnecessary.
- ❹ Use a reinforcement steel plate of at least 3.2 mm thick and 200 mm long.

Fixed Receptive Base
U-3N type

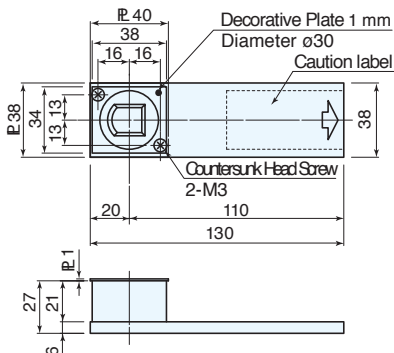

Fixed Receptive Base
U-2N type

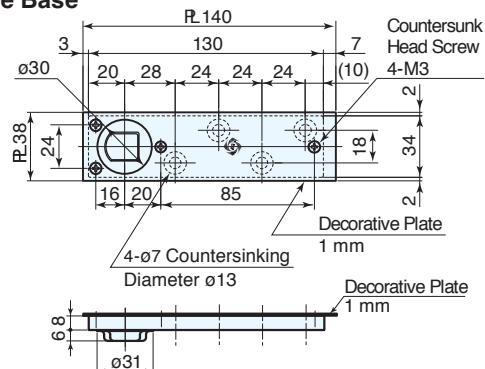

U-2N Receptive Base size

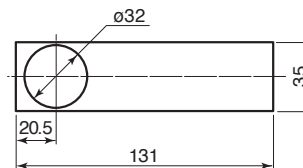

- U-2N is compatible with all models from AFD-12H to 16H.

- Receptive Base for smoke ventilation-
U-2NH type

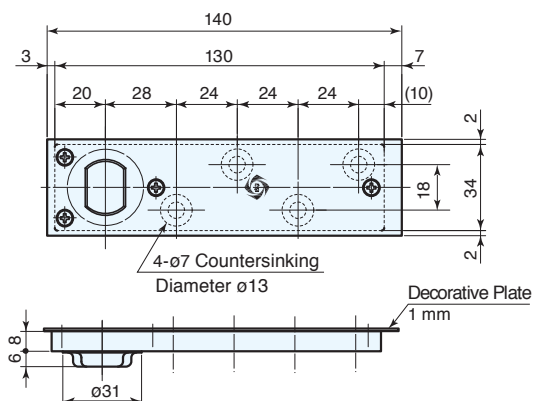
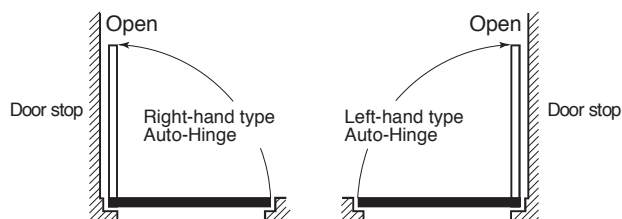

- When using for the smoke ventilations or air intake doors (automatic opening), use the Auto-Hinge left and right opposite. Also use the U-2NH receptive base.

Unit: mm

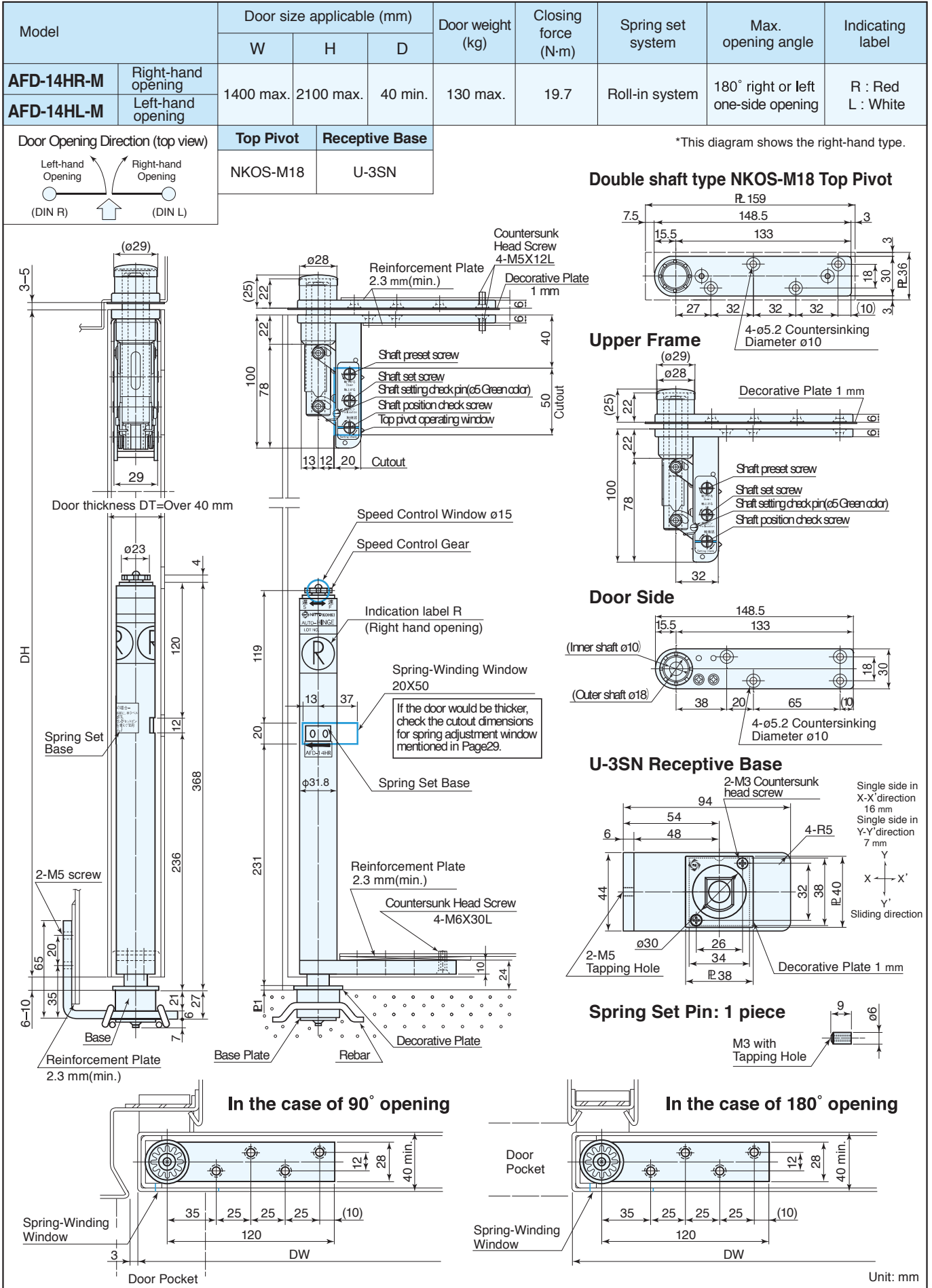

Receptive Base (Option)

Fixed Receptive Base U-3N type

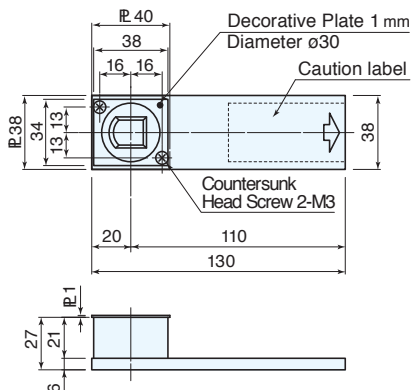

Fixed Receptive Base U-2N type

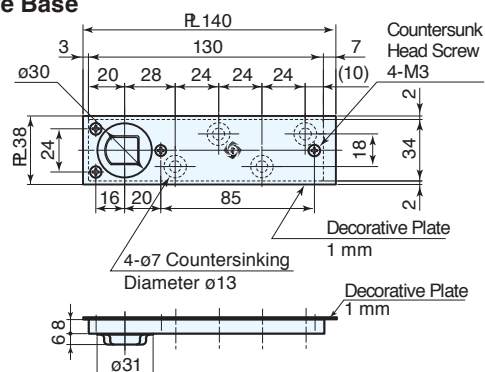

U-2N Receptive Base size

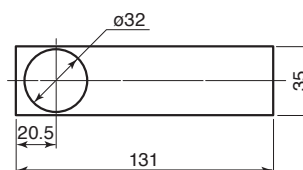

● U-2N is compatible with all models from AFD-12H to 16H.

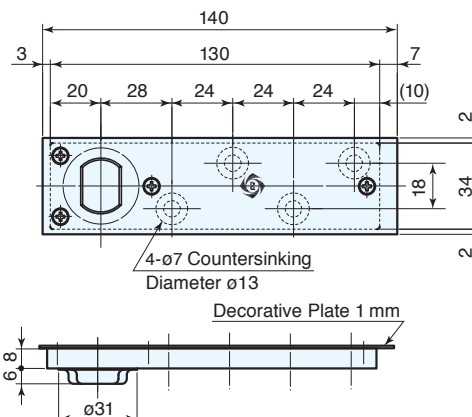

- Receptive Base for smoke ventilation- U-2NH type

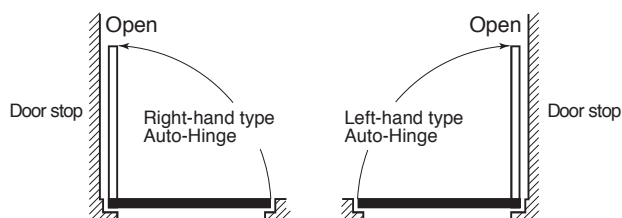

● When using for the smoke ventilations or air intake doors (automatic opening), use the Auto-Hinge left and right opposite. Also use the U-2NH receptive base.

- Receptive Base for wicket door with no lower frame - NU-3LA type

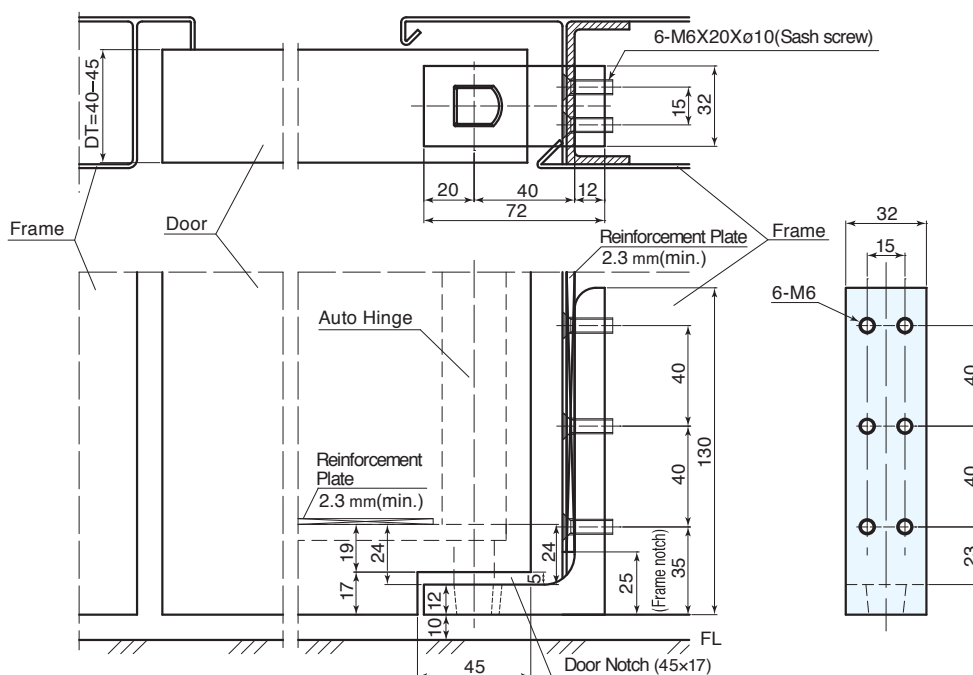

- ① Applicable wicket door size: 130 kg or less in weight, 40-45 mm in door thickness. (Compatible with A-8KH to 14H, AFD-8KH to 14H)
- ② For NU-3LA, use a reinforcement steel plate of at least 3.2 mm thick and 200 mm long. For Auto-Hinge, use a reinforcement steel plate of at least 2.3 mm thick and 200 mm long.
- ③ NU-3LA is non handed, can be used for the left-hand and right-hand doors.
- ④ Surface treatment: Trivalent chromate plating (white).

Unit: mm

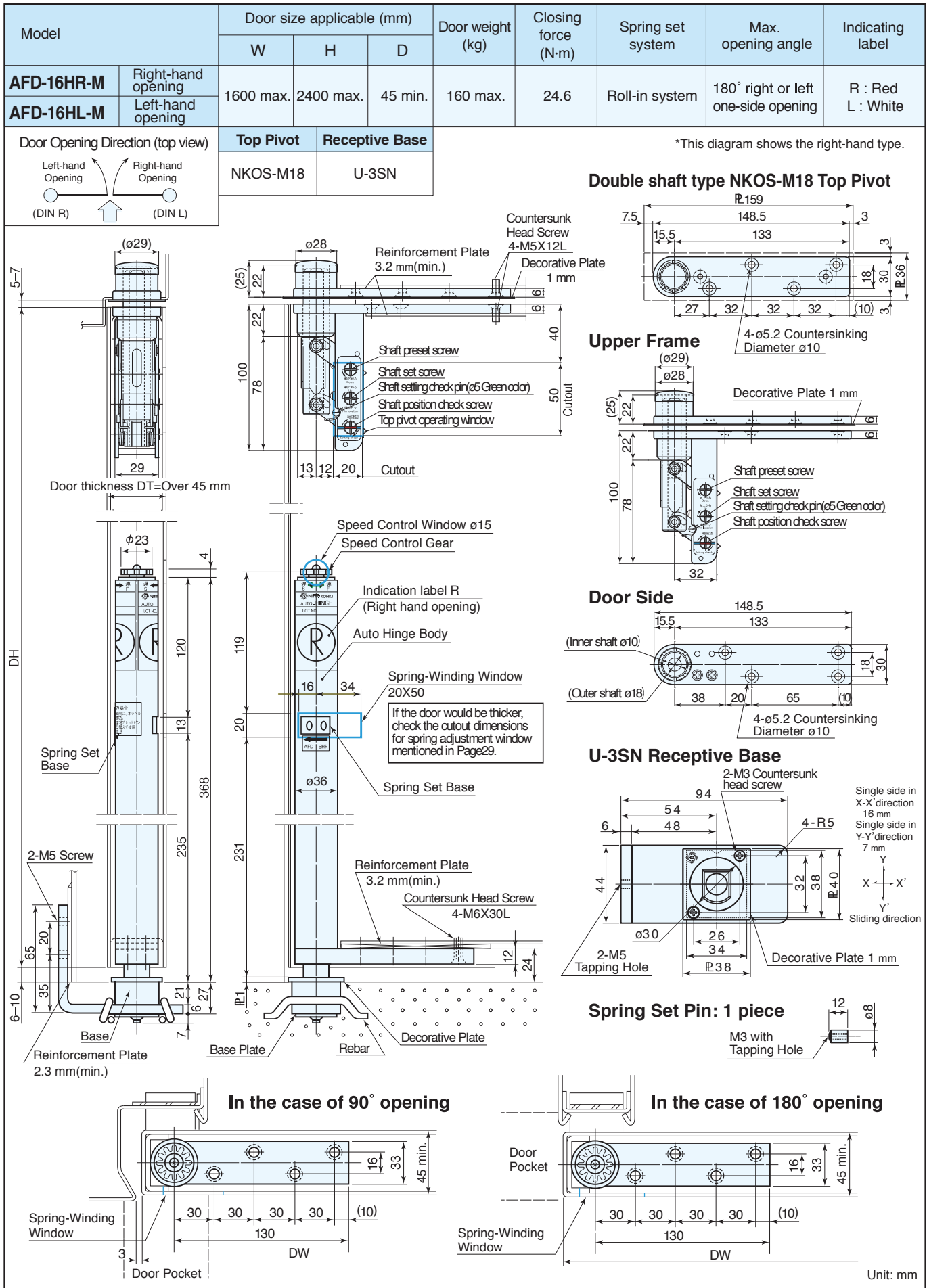

REMARKS

1. This diagram shows the installation example of right-hand opening doors. There is a spring winding-window on both sides of hinge main body.
2. To cover the door cutouts for speed control window and spring-winding window, use the decorative rubber plate supplied with the product. (See page 29)
3. The receptive base must be adjusted and centered by using a plumb bob from the top pivot. The base must be firmly welded onto the base plate.
4. When inserting the set pin into the set hole, use the set pin mounting screws (M3X50) supplied with the product.

Receptive Base (Option)

Fixed Receptive Base U-3N type

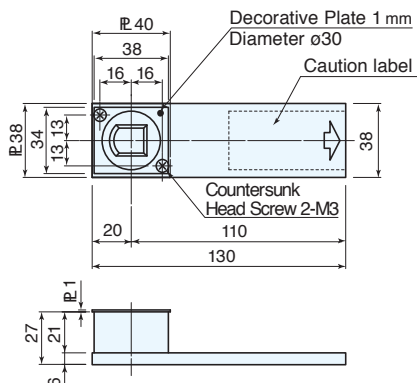

- Receptive Base for smoke ventilation- U-2NH type

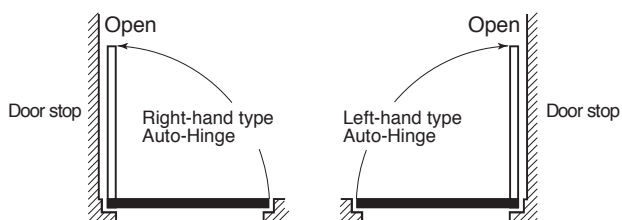

● When using for the smoke ventilations or air intake doors (automatic opening), use the Auto-Hinge left and right opposite. Also use the U-2NH receptive base.

Fixed Receptive Base U-2N type

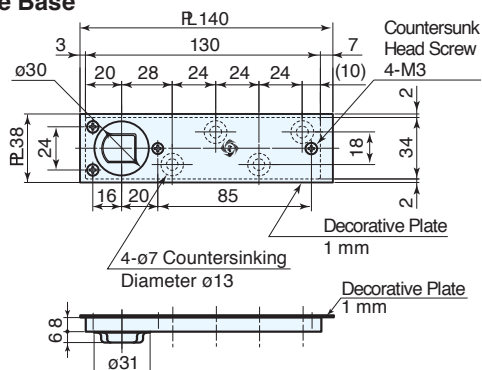

U-2N Receptive Base size

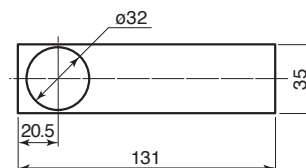

● U-2N is compatible with all models from AFD-12H to 16H.

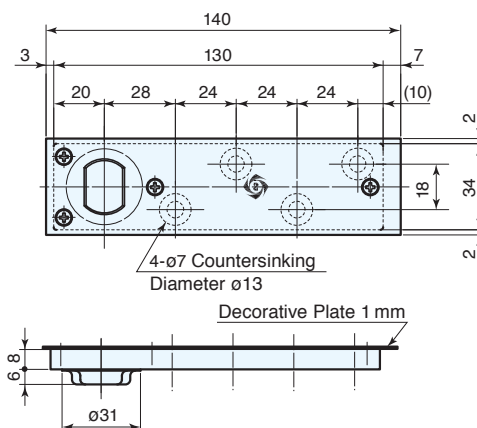

Unit: mm

Model		Door size applicable (mm)			Door weight (kg)	Closing force (N·m)	Spring set system	Max. opening angle	Indicating label
		W	H	D					
AFD-22-M	Right-hand opening	2200 max.	2400 max.	50 min.	240 max.	49.1	Roll-in system	180° right or left one-side opening	R : Red L : White
AFD-22-M	Left-hand opening								

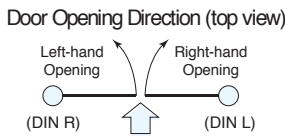

Top Pivot	Receptive Base
NKOS-M18	U-6SN

*This diagram shows the right-hand type.

Double shaft type NKOS-M18 Top Pivot

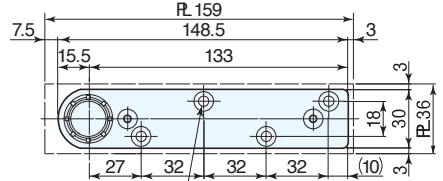

Upper Frame

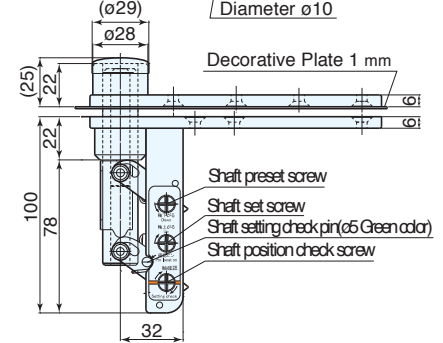

Door Side

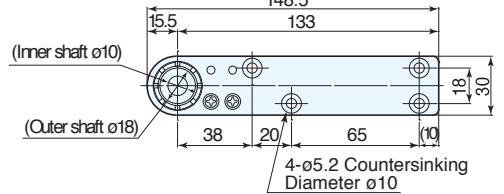

U-6SN Receptive Base

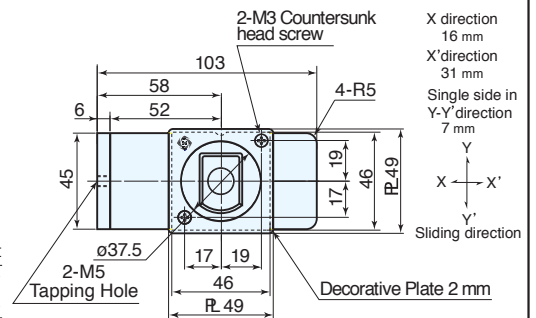

Spring Set Pin: 2 piece



In the case of 90° opening

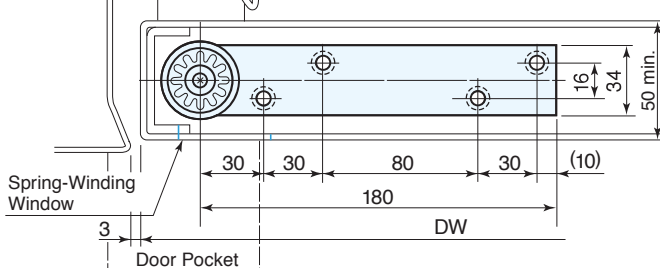

In the case of 180° opening

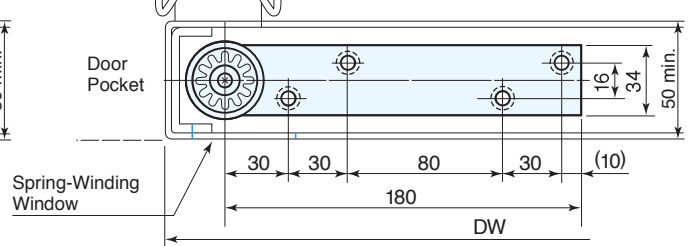

Unit: mm

REMARKS

1. This diagram shows the installation example of right-hand opening doors.
2. To cover the door cutouts for speed control window and spring-winding window, use the decorative rubber plate supplied with the product. (See page 29)
3. The receptive base must be adjusted and centered by using a plumb bob from the top pivot. The base must be firmly welded onto the base plate.
4. When inserting the set pin into the set hole, use the set pin mounting screws (M3X50) supplied with the product.

Receptive Base (Option)

Fixed Receptive Base U-6N type

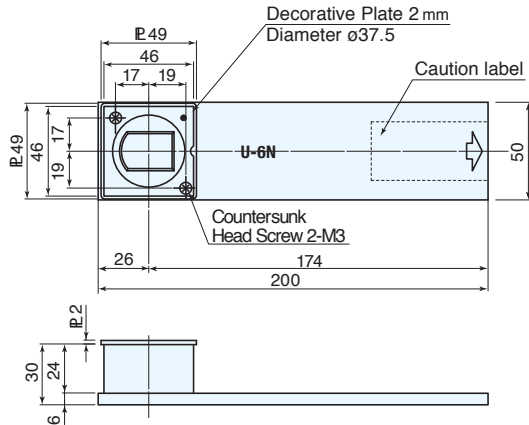

Unit: mm

Reverse side spring adjustment window - For special application (reference drawing) AFD-22P type (Special order model)

In the case of 90° opening

This diagram shows the right-hand type.

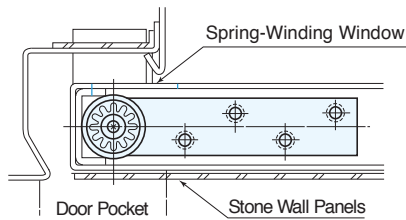

In the case of 180° opening

This diagram shows the right-hand type.

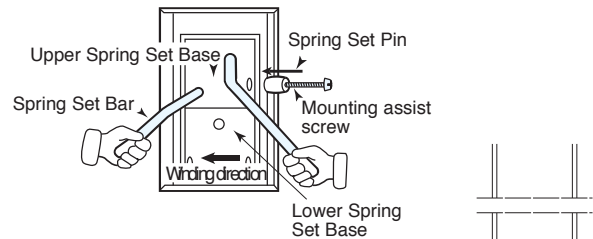
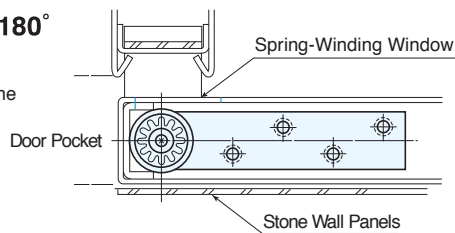

Opening Direction

- The spring must be wound towards the door opening direction (towards front end of the door).

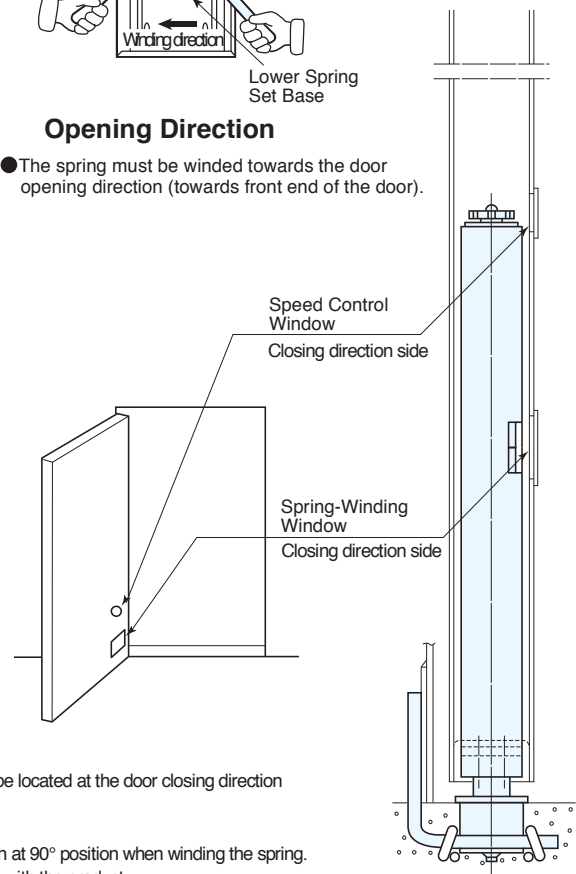

- 1 This model is suitable for a special application where the adjustment windows are intended to be located at the door closing direction (e.g. normally-closed fire door etc.)
- 2 AFD-22P has the spring adjustment window at reverse side of regular models.
- 3 In order to prevent interference with the vertical door frame at hanging side, keep the door open at 90° position when winding the spring.
- 4 When inserting the set pin into the set hole, use the set pin mounting screws (M3X50) supplied with the product.

Model		Door size applicable (mm)			Door weight (kg)	Closing force (N·m)	Spring set system	Max. opening angle	Indicating label
		W	H	D					
AFD-30-M	Right-hand opening	3000 max.	2600 max.	55 min.	410 max.	68.7	Roll-in system	180° right or left one-side opening	R : Red L : White
AFD-30-M	Left-hand opening								

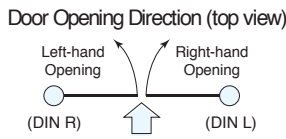

Top Pivot	Receptive Base
NKOS-M20	U-7SN

*This diagram shows the right-hand type.

Double shaft type NKOS-M20 Top Pivot

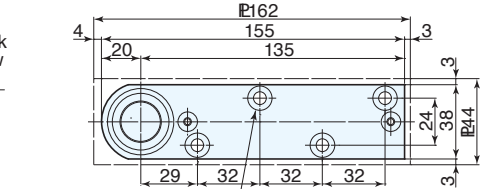

Upper Frame

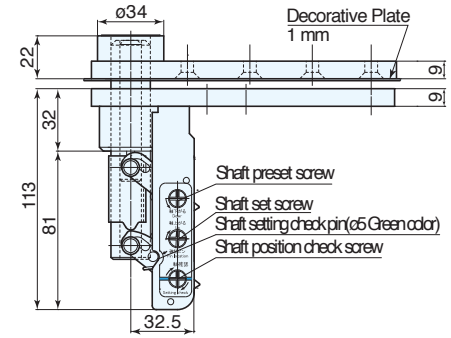

Door Side

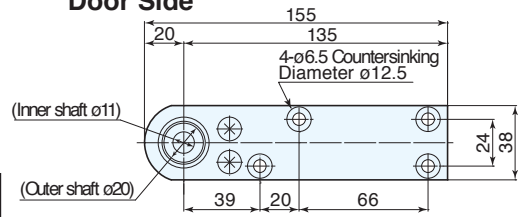

U-7SN Receptive Base

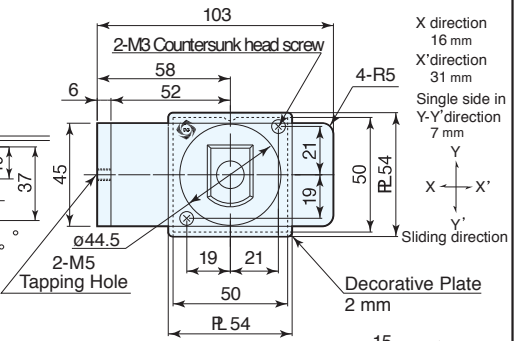

Spring Set Pin: 2 piece

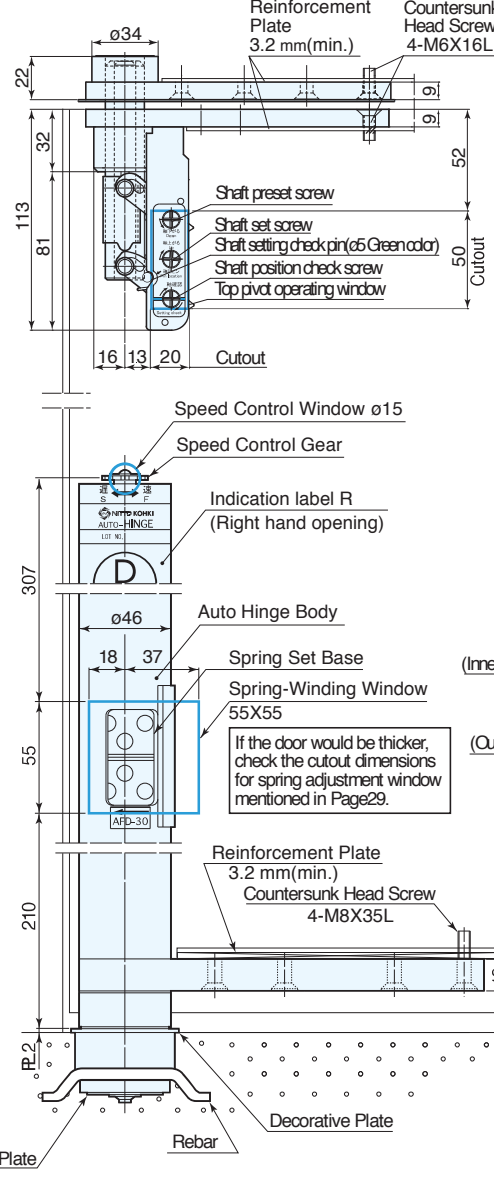
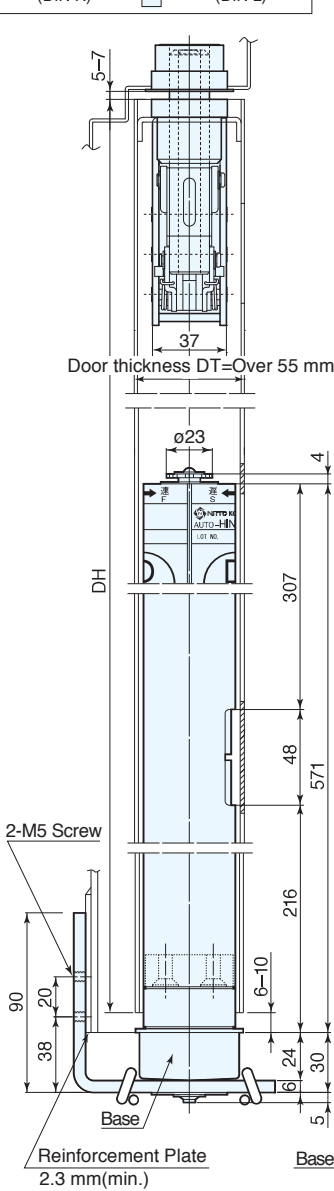
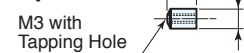

In the case of 90° opening

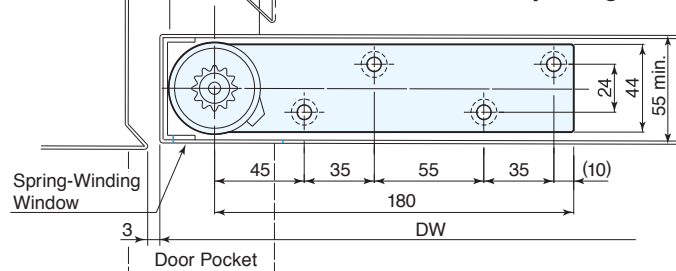

In the case of 180° opening

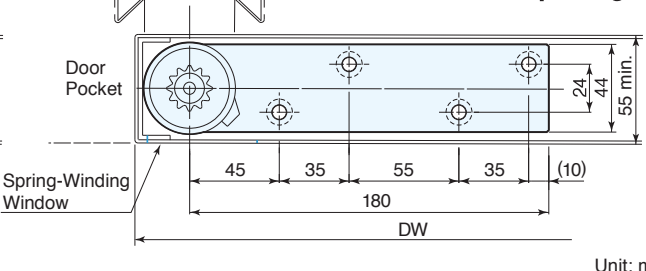

Unit: mm

REMARKS

- This diagram shows the installation example of right-hand opening doors.
- To cover the door cutouts for speed control window and spring-winding window, use the decorative rubber plate supplied with the product. (See page 29)
- The receptive base must be adjusted and centered by using a plumb bob from the top pivot. The base must be firmly welded onto the base plate.
- When inserting the set pin into the set hole, use the set pin mounting screws (M3X50) supplied with the product.

Receptive Base (Option)

Fixed Receptive Base U-7N type

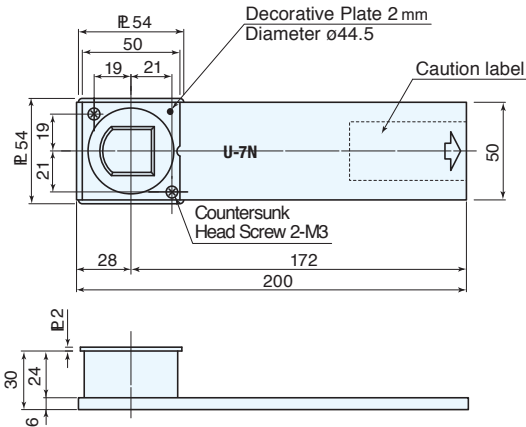

Unit: mm

Reverse side spring adjustment window - For special application (reference drawing) AFD-30P type (Special order model)

In the case of 90° opening

This diagram shows the right-hand type.

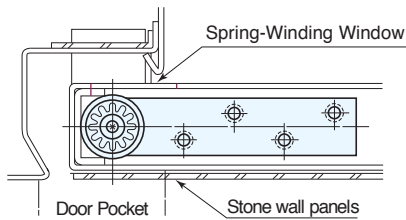

In the case of 180° opening

This diagram shows the right-hand type.

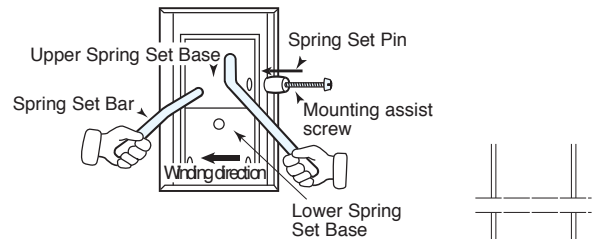
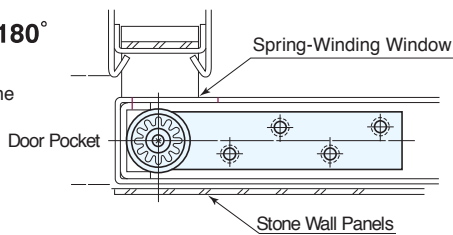

Opening Direction

- The spring must be wound towards the door opening direction (towards front end of the door).

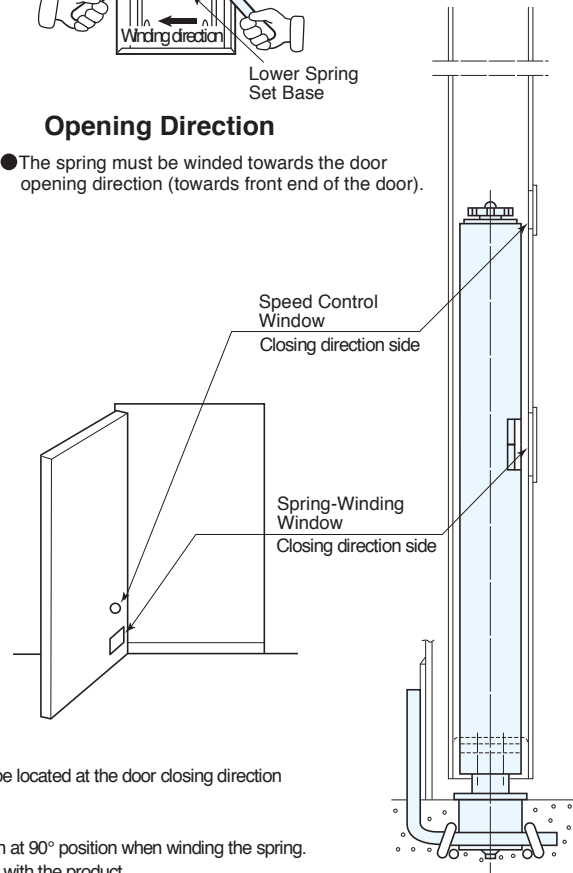

- 1 This model is suitable for a special application where the adjustment windows are intended to be located at the door closing direction (e.g. normally-closed fire door etc.)
- 2 AFD-30P has the spring adjustment window at reverse side of regular models.
- 3 In order to prevent interference with the vertical door frame at hanging side, keep the door open at 90° position when winding the spring.
- 4 When inserting the set pin into the set hole, use the set pin mounting screws (M3X50) supplied with the product.

Model		Door size applicable (mm)			Door weight (kg)	Closing force (N·m)	Spring set system	Max. opening angle	Indicating label
		W	H	D					
AFD-35A-M	Right-hand opening	3500 max.	3000 max.	55 min.	650 max.	73.6	Roll-in system	180° right or left one-side opening	R : Red L : White
AFD-35A-M	Left-hand opening								

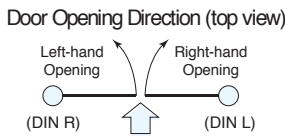

Top Pivot	Receptive Base
NKOS-M20	U-7SN

*This diagram shows the right-hand type.

Double shaft type NKOS-M20 Top Pivot

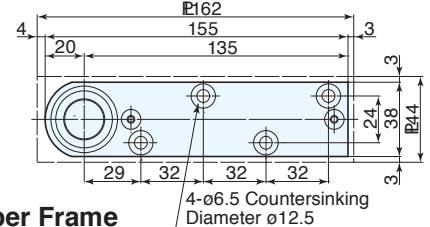

Upper Frame

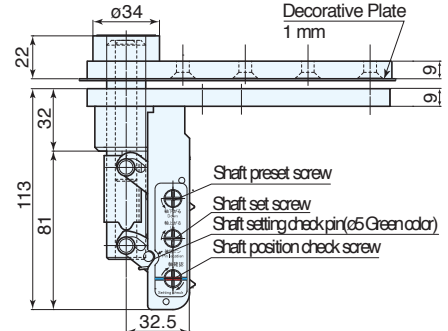

Door Side

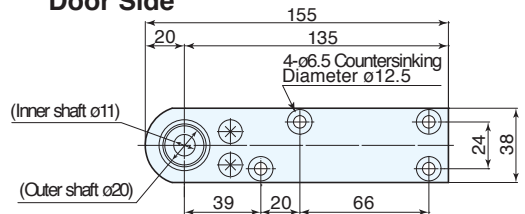

U-7SN Receptive Base

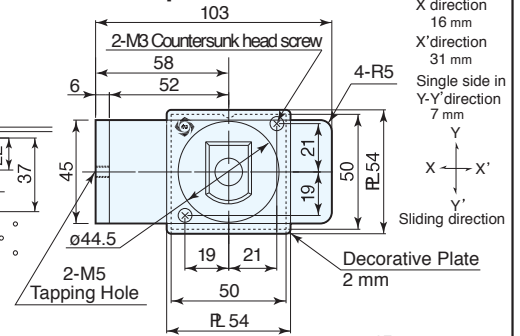

Spring Set Pin: 2 piece



In the case of 90° opening

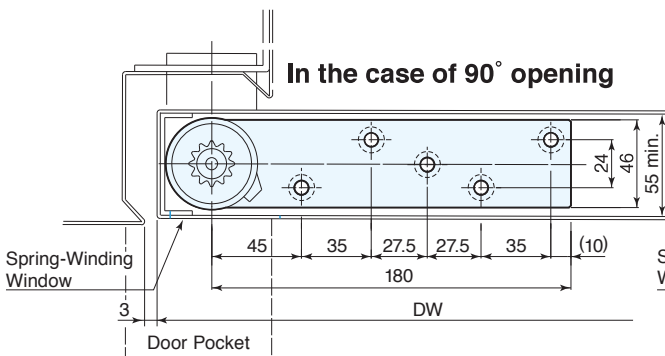

In the case of 180° opening

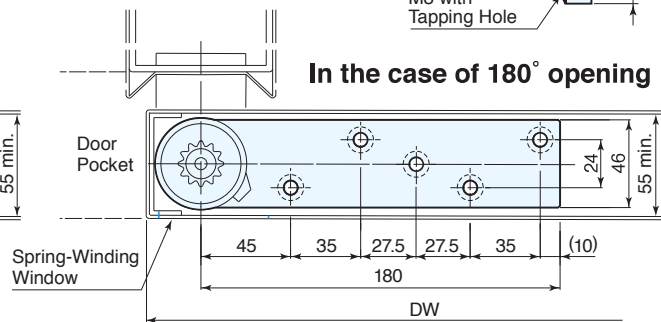

Unit: mm

REMARKS

1. This diagram shows the installation example of right-hand opening doors.
2. To cover the door cutouts for speed control window and spring-winding window, use the decorative rubber plate supplied with the product. (See page 29)
3. The receptive base must be adjusted and centered by using a plumb bob from the top pivot. The base must be firmly welded onto the base plate.
4. When inserting the set pin into the set hole, use the set pin mounting screws (M3X50) supplied with the product.

Receptive Base (Option)

Fixed Receptive Base U-7N type

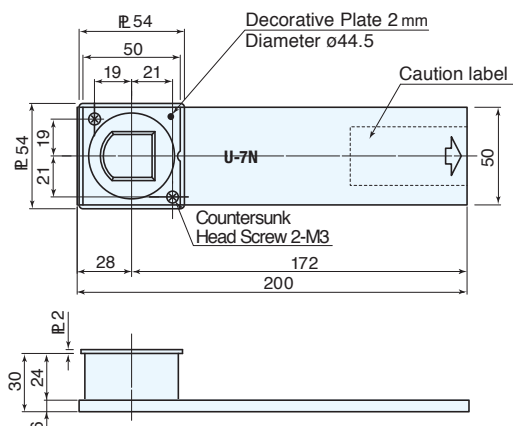

Unit: mm

Reverse side spring adjustment window - For special application (reference drawing) AFD-35AP type (Special order model)

In the case of 90° opening

This diagram shows the right-hand type.

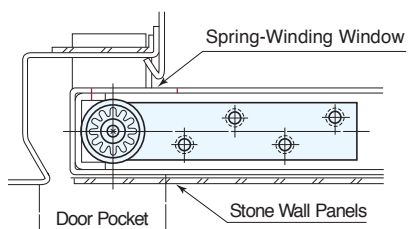

In the case of 180° opening

This diagram shows the right-hand type.

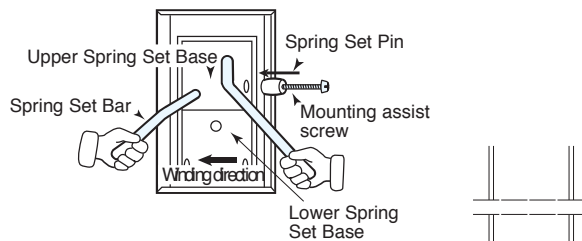
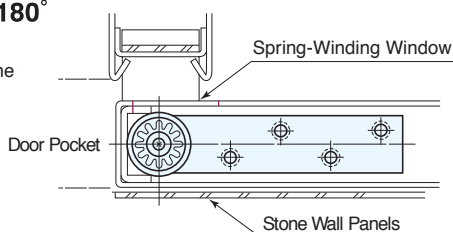

Opening Direction

- The spring must be wound towards the door opening direction (towards front end of the door).

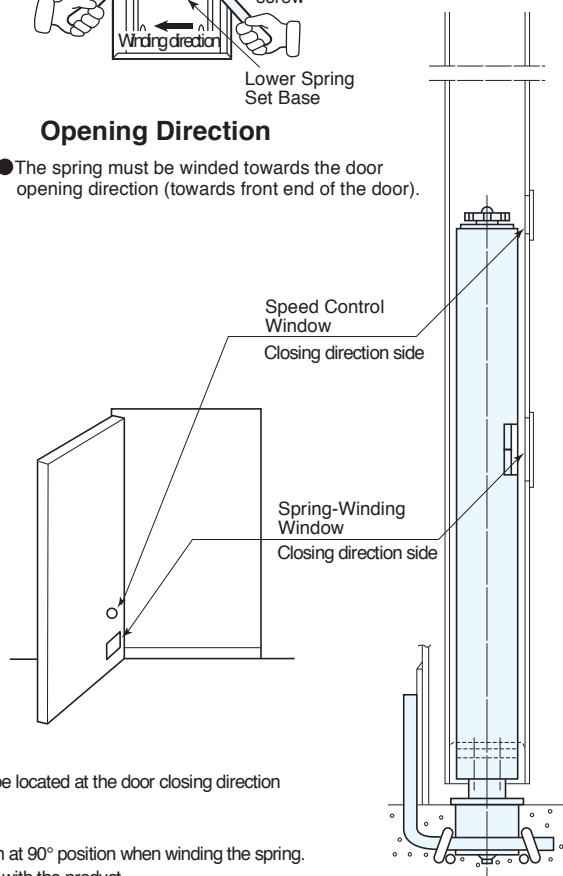

- 1 This model is suitable for a special application where the adjustment windows are intended to be located at the door closing direction (e.g. normally-closed fire door etc.)
- 2 AFD-35AP has the spring adjustment window at reverse side of regular models.
- 3 In order to prevent interference with the vertical door frame at hanging side, keep the door open at 90° position when winding the spring.
- 4 When inserting the set pin into the set hole, use the set pin mounting screws (M3X50) supplied with the product.

Confirm the door opening direction

Check the opening direction of the door as per the following diagram.

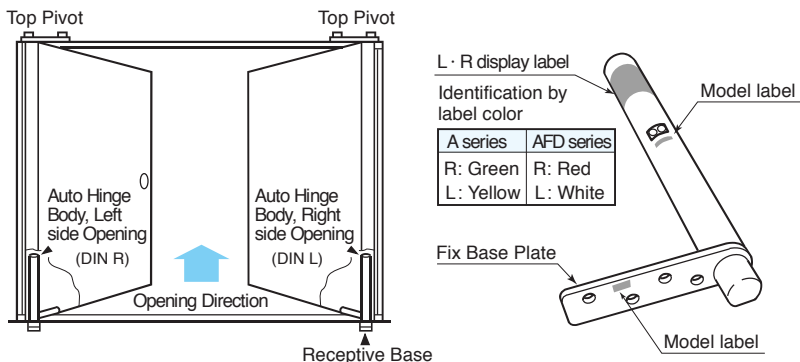

L · R display label
Identification by label color

A series	AFD series
R: Green	R: Red
L: Yellow	L: White

Make sure that the door cutouts for the speed control window and spring-winding window are prepared at the opening side.

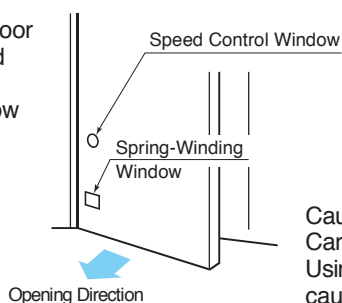

Remove the protective screen seal on the label surface when the model number becomes hard to see by paint etc.

Caution:
Carefully check the opening direction. Using the wrong hand model will cause defect.

Reinforcing the door

Provide suitable reinforcement plates and channel plates according to the following Table.

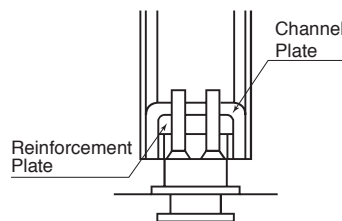
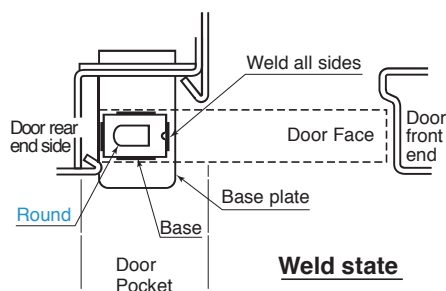
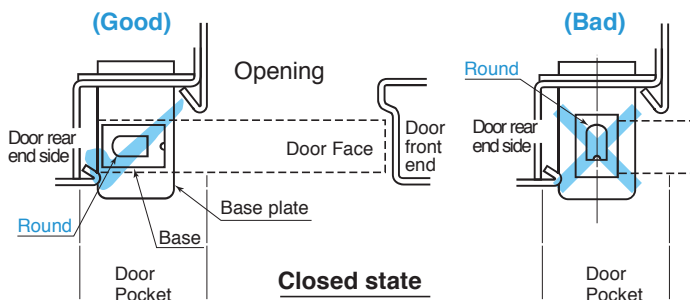

Plate thickness		Thickness of reinforcement plate/channel plate (mm)
Model		
A-8KH	AFD-8KH	2.3 min.
A-12H	AFD-12H	
A-14H	AFD-14H	
A-16H	AFD-16H	3.2 min.
A-22	AFD-22	
A-30	AFD-30	
A-35A	AFD-35A	4.5 min.
A-40A	—	9.0 min.

Setting the fix base plate

- Make sure that the round side of the receptive base channel faces to the door rear end side when door is closed.
- Slide the receptive base on the base plate for fine adjustment. Use plumb bob and align the base properly.
- After the alignment is completed, weld the base and the base plate properly.



Cautions for Handling

- 1 Do not strike or drop.
- 2 Do not turn the hinge lower leg (spindle part).
- 3 Do not joint by welding.
- 4 Do not scrape/grind the tapered part of the hinge lower leg (spindle part).

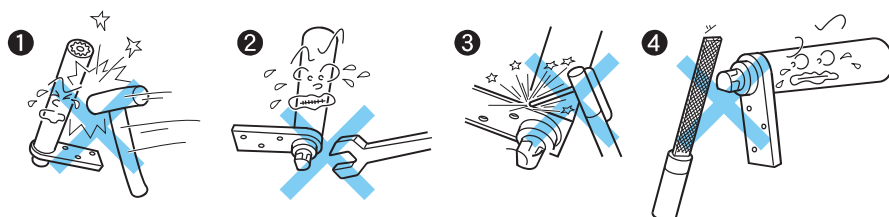

Mounting the Top Pivot

Do not install the Top Pivot before the door/frame construction is completed. Do not carry out any hot works on the door/frame after the Top Pivot is installed. The bearing may get deformed due to the heat of welding or baking finish and the shaft may not properly fit in, resulting the door fall down.

Roll-in system (A(AFD)-8KH-40A) : Door hanging and spring winding procedures

- 1 Make sure that the door cutouts for the speed control window and spring-winding window are prepared at the opening side (door pocket side).
- 2 Make sure that the hinge lower leg (spindle part) securely fits into the receptive base channel. Carefully check the direction of round part. (If the spindle and base channel are not fixed properly, the door will not be hung in position.) If the spindle does not fit in the receptive channel well, turn the hinge lower leg (spindle part) and match the "I" mark.
- 3 Incline the door, insert the hinge lower leg (spindle part) into the Receptive Base and then carefully stand the door.
- 4 After confirming that the hinge lower leg (spindle part) is securely set in the receptive base, align the Top Pivot in center. Properly set the shaft for the Top Pivot.
- 5 After hanging the door, wind the spring with the spring set bar. First, wind the upper spring set base towards the direction of door opening and insert the set pin into the spring set pin hole (ref. Table 5 below). After that, wind the lower spring set base and insert the set pin in same manner as above. (A(AFD)-8KH-16H models only have the upper spring set base.)

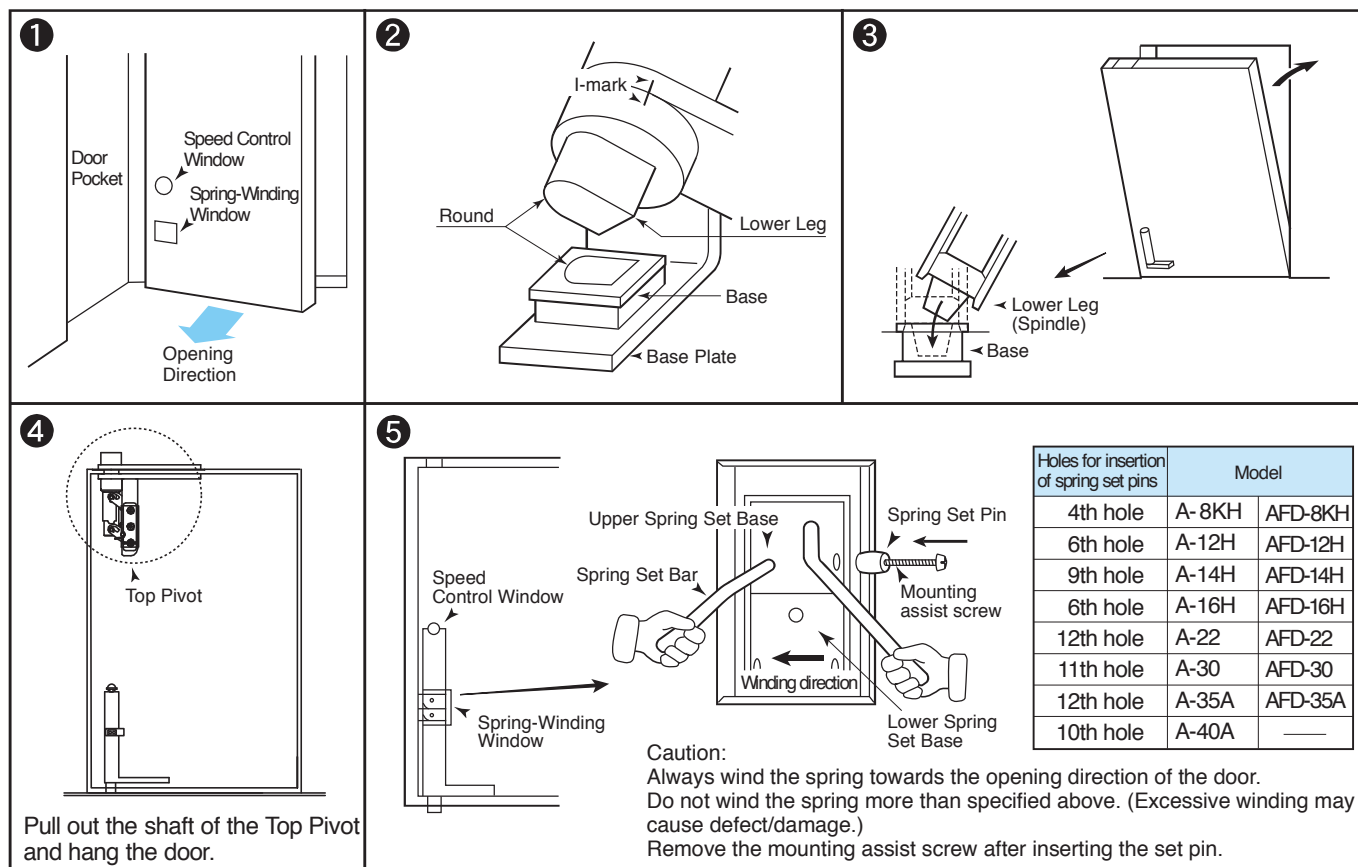

This diagram shows the right-hand type.

Closing speed adjustment

- After hanging the door and setting the spring, insert a screwdriver through the speed control window and turn the speed control gear.
 - Turning clockwise → **Slower**
 - Turning counterclockwise ← **Faster**

(The gear does not move up or down with turning.)

- Maximum # of turns : 18 turns
- After continuously turning the gear, once it comes to be heavy, that is the maximum point of turning.
- Do not turn the gear further than the maximum point. Excessive turn may cause defect/damage.

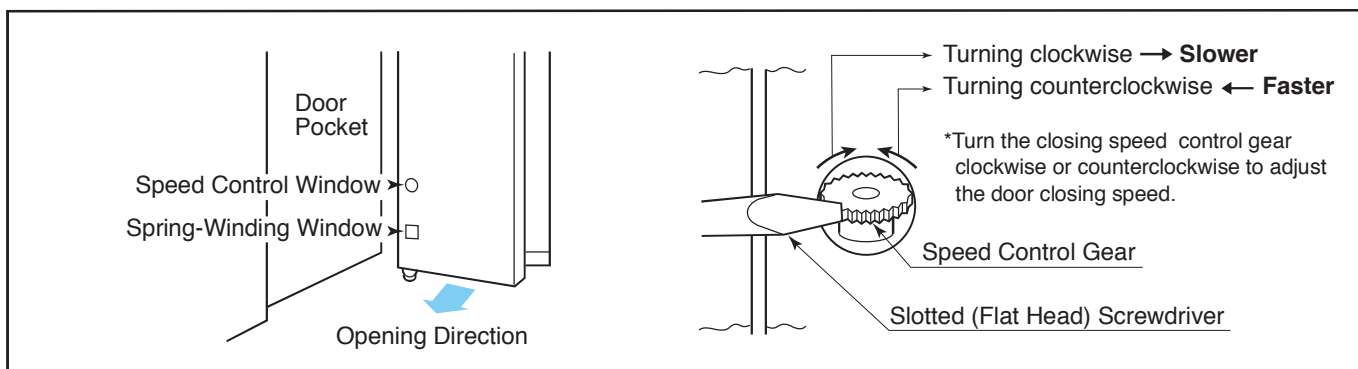

Decorative Rubber Plate

Dimension drawing Color: gray

For Spring-Winding Window

- SQUARE TYPE (With Round) (AFD-8KH, A-8KH)

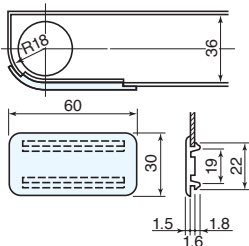

- SQUARE TYPE (Small) (AFD-12H, AFD-14H, AFD-16H, A-12H, A-14H, A-16H)

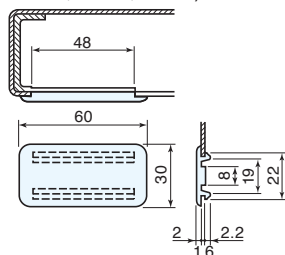

- SQUARE TYPE (Large) (AFD-22, AFD-30, AFD-35A, A-22, A-30, A-35A, A-40A)

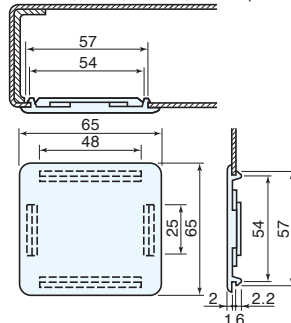

For Speed Control Window

- ROUND TYPE (AFD-8KH-35A, A-8KH-A-40A)

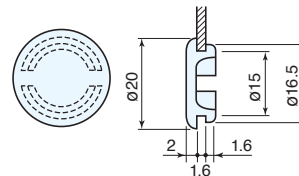

Dimension drawing for door cutout

- Applicable Models (A-8KH, A-12H, A-14H, A-16H, AFD-8KH, AFD-12H, AFD-14H, AFD-16H)

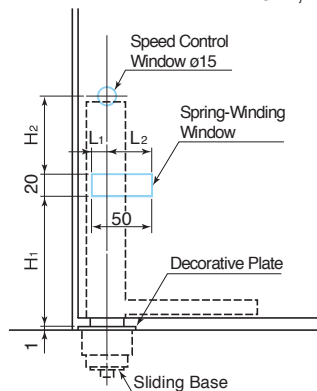

Model	H ₁	H ₂	L ₁	L ₂
A-8KH / AFD-8KH	105	106	12	38
A-12H / AFD-12H	181	109	13	37
A-14H / AFD-14H	231	119	16	34
A-16H / AFD-16H				

- Applicable Models (A-22, A-30, A-35A, A-40A, AFD-22, AFD-30, AFD-35A)

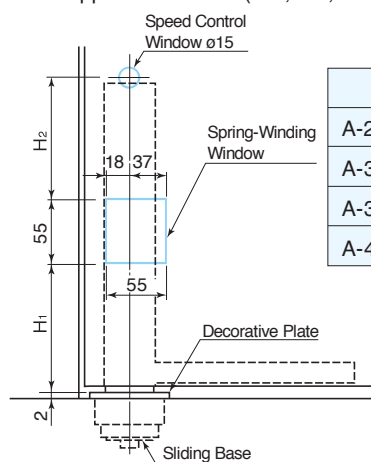

Model	H ₁	H ₂
A-22 / AFD-22	181	266
A-30 / AFD-30	210	307
A-35A / AFD-35A		
A-40A	219	298

Unit: mm

Cutout dimension of the spring-winding window for each door thickness

Door thickness (mm)		40	45	50	55	60	65	70	75	80	85	90	95	100
A-8KH	AFD-8KH	L=12 (Standard door thickness)						L=13		L=14		L=15		
A-12H	AFD-12H	L=13 (Standard door thickness)							L=14		L=15		L=16	
A-14H	AFD-14H	L=13 (Standard door thickness)			L=14	L=15	L=16	L=17		L=18	L=19	L=20		
A-16H	AFD-16H	L=16 (Standard door thickness)	L=17	L=18	L=19	L=21	L=22	L=23	L=24	L=25	L=26	L=27	L=29	
A-22	AFD-22	L=18 (Standard door thickness)												
A-30, A-35A, A-40A	AFD-30, AFD-35A	L=18 (Standard door thickness)												

- * 1. The value "L" represents the cutout dimension from the hinge pivot center to the edge of cutout window at the door hanging side. (unit: mm)
- 2. When the door exceeds the standard thickness, the decorative plate (provided as standard) cannot be used.

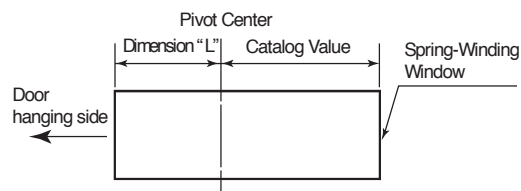

Fixed Receptive Base

U-3N

(A-8KH – A-16H)

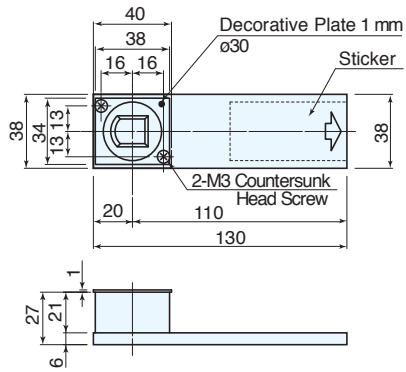

U-6N

(A-22)

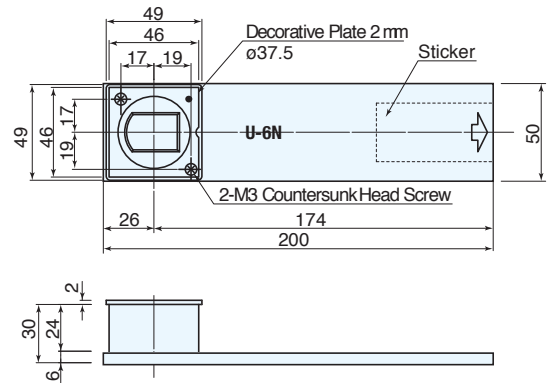

U-7N

(A-30 – A-35A)

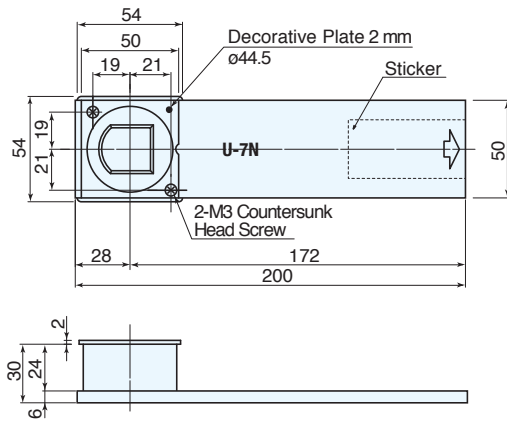

U-2NH

(A-8KH – A-16H)

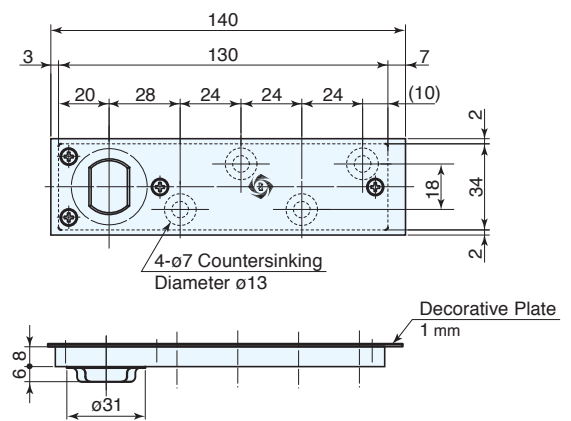

Unit: mm

User-friendly technology

Door Closer

Auto Hinge & Sliding Door Closer

OTHER RELATED PRODUCTS

AUTO-HINGE

Flag Type

■ Door Closer + hinge, All-In-One.
Designed with cutting edge technology from Nitto Kohki. Easy to install on all kinds of swing doors (regular rectangle doors, arch doors, etc).

■ Variety of models available for different size and type of doors (wooden, aluminum, lightweight steel, steel and glass doors).



Butterfly Type

- Small and slim, ideal for lightweight doors (indoor use).
- The butterfly design makes installation highly efficient.
- Non handed - Can be used for both right and left hand opening doors.



PC series

- Drip-proof design, suitable for outdoor use or moist area.
- Adopts an actuator with unique temperature sensor, ensuring consistent closing speed all year round.



700 series

- Made in highly durable stainless steel with special sealing mechanism.
- Commercial grade, widely applicable for various locations including bathrooms, seashores etc.

Door Closer

Sliding Door Closer

Innovative solution adding self-closing feature to your sliding door. Also designed to assist in reducing the door opening resistance to achieve an easy and safe operation.

Horizontal model for bathroom
NSC-CB

Horizontal model
NSC-C

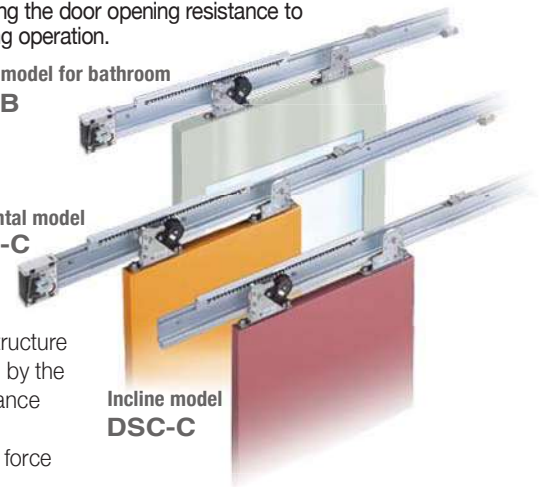

Incline model
DSC-C

- Compact design, lightweight structure and long-life time are achieved by the unique endless viscosity resistance system (patented).
- Easy to adjust the door closing force and speed.

DISTRIBUTED BY



This catalog is printed with vegetable oil inks, using natural energy from wind power generation.

NITTO KOHKI CO., LTD.

DOOR CLOSERS Sales Dept :

8F, VORT Ueno, 4-7, Ueno 7-chome, Taito-ku,
Tokyo 110-0005, Japan
Tel : +81-3-5806-1030 Fax : +81-3-3843-5188
E-mail : Kentokyo@nitto-kohki.co.jp

Head Office:

9-4, Nakaikegami 2-chome, Ohta-ku,
Tokyo 146-8555, Japan

Web www.nitto-kohki.co.jp/e



JQA-2025
JQA-EM4057
H.Q./R&D Lab



 **KENWA**

Open to new possibilities