

# PIVOT HINGES

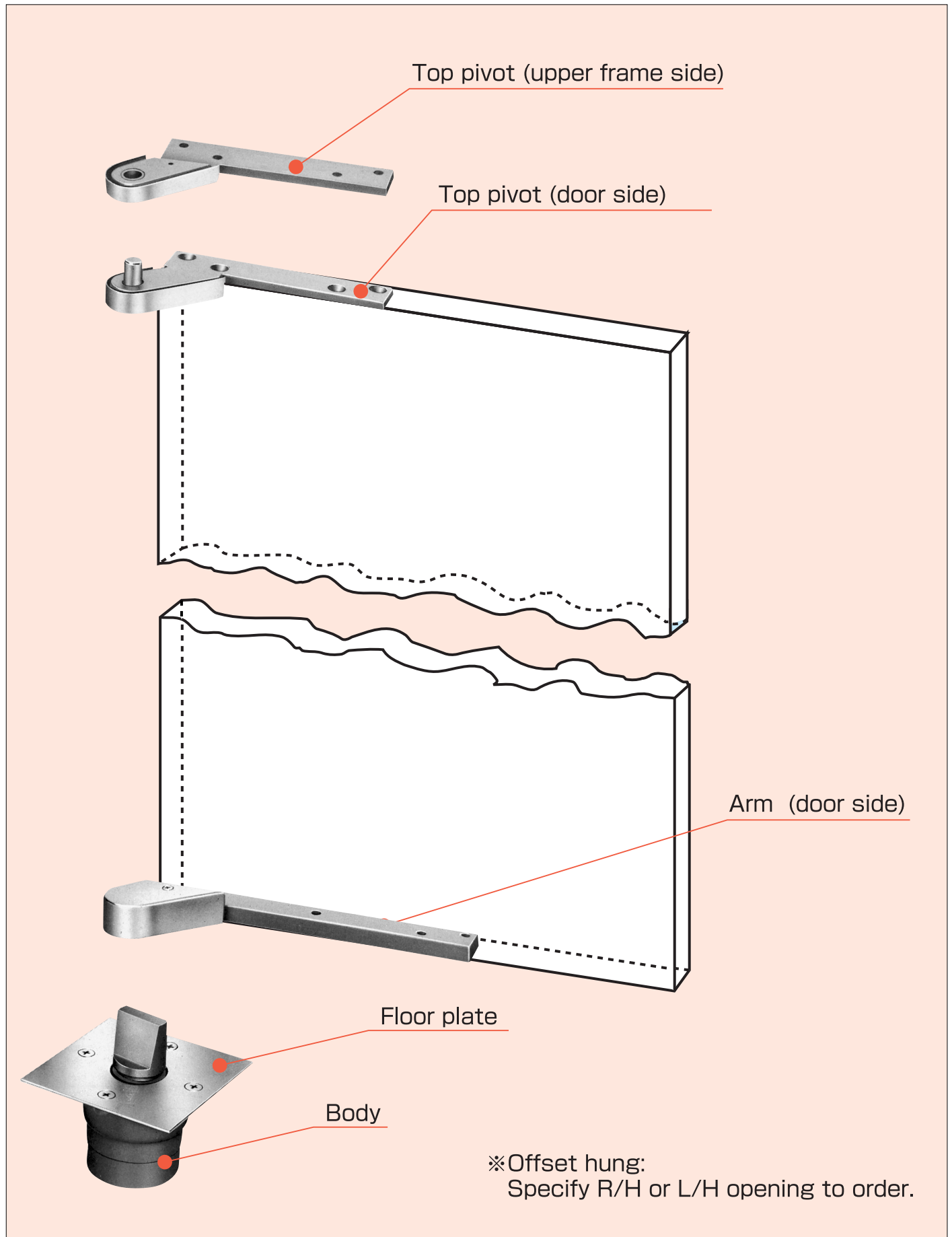

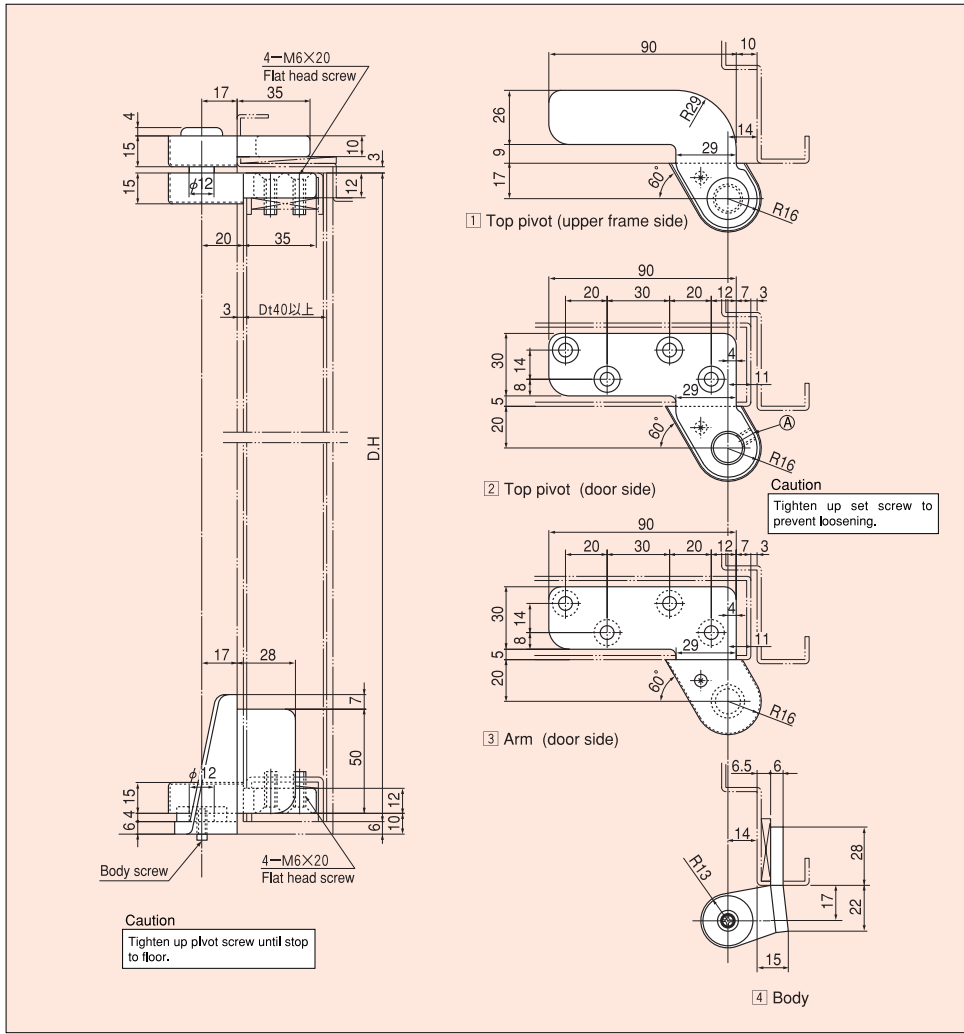

# 11-D

## OFFSET HUNG (Steel Door)

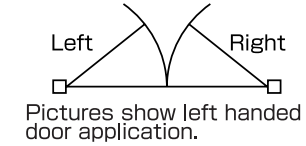

<b>MAXIMUM DOOR</b>	
D.W×D.H (mm)	900×2100
DOOR WEIGHT (kg)	80

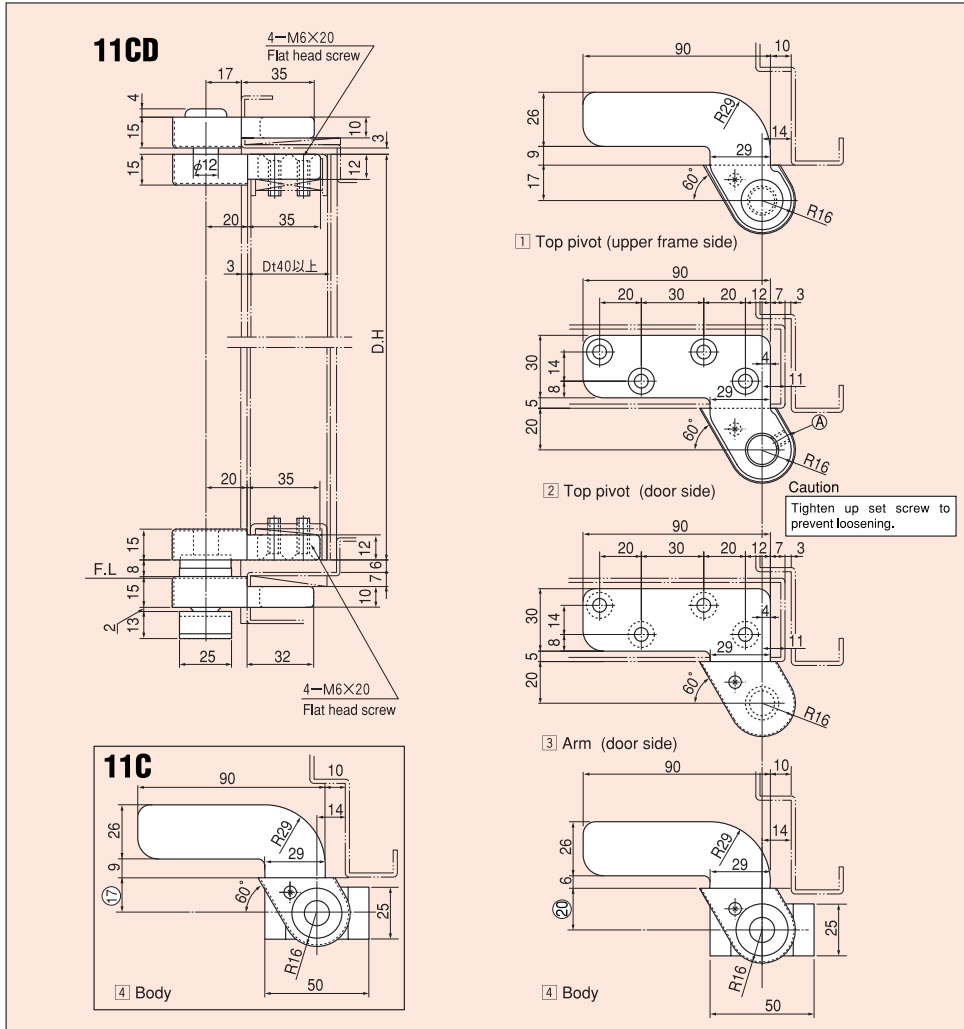

# 11CD · 11C

## OFFSET HUNG (Steel Door)

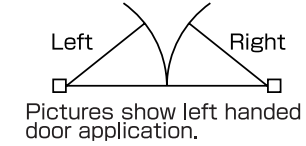

<b>MAXIMUM DOOR</b>	
D.W×D.H (mm)	900×2100
DOOR WEIGHT (kg)	80

# 13CD·13C

OFFSET HUNG  
(Steel Door)

## 13CD

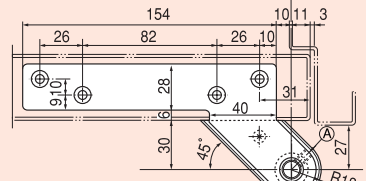
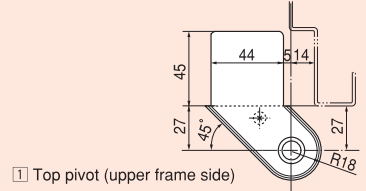
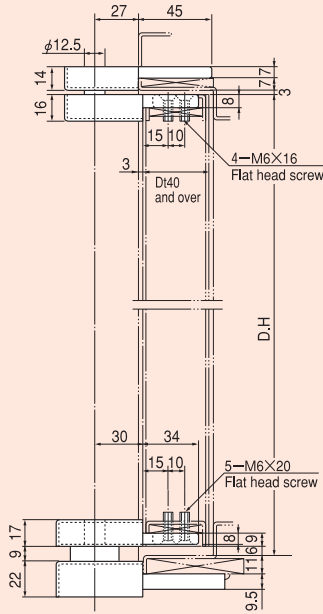

Caution  
Tighten up set screw to prevent loosening.

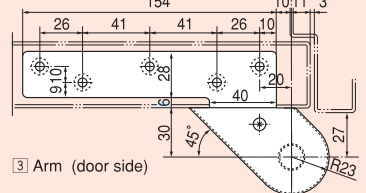

## 13C

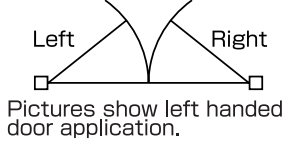
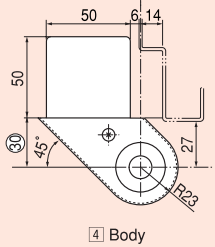
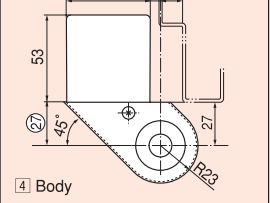

### MAXIMUM DOOR

D.W×D.H (mm)	1050×2200
DOOR WEIGHT (kg)	120

# 2CAD·2CA

OFFSET HUNG  
(Steel Door)

## 2CAD

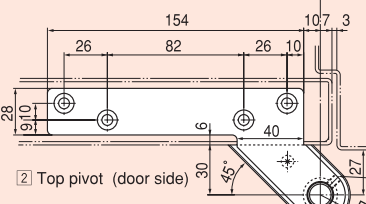
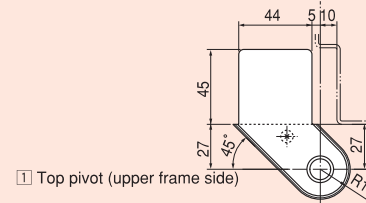
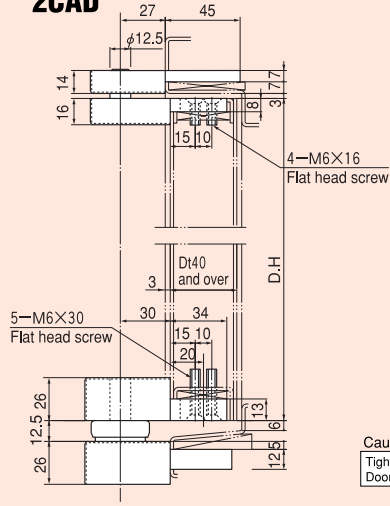

Caution  
Tighten up set screw to prevent loosening.  
Door stop must be installed.

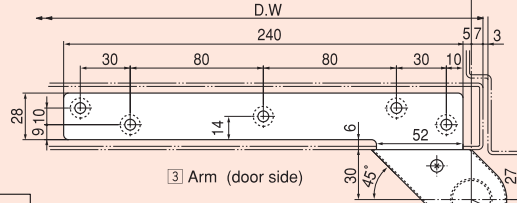

## 2CA

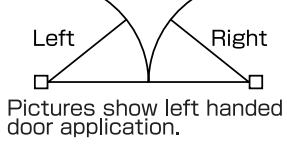
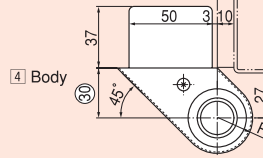
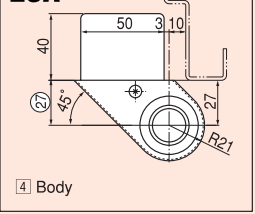

### MAXIMUM DOOR

D.W×D.H (mm)	1500×2400
DOOR WEIGHT (kg)	180

### 3CAD

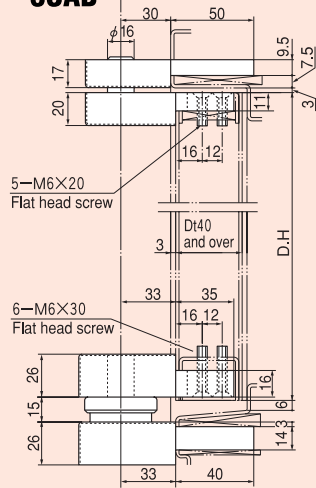

1 Top pivot (upper frame side)

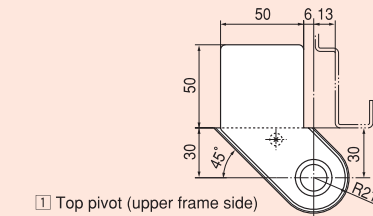

Caution  
Tighten up set screw to prevent loosening.  
Door stop must be installed.

2 Top pivot (door side)

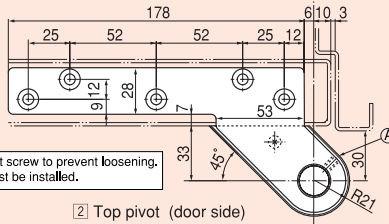

3 Arm (door side)

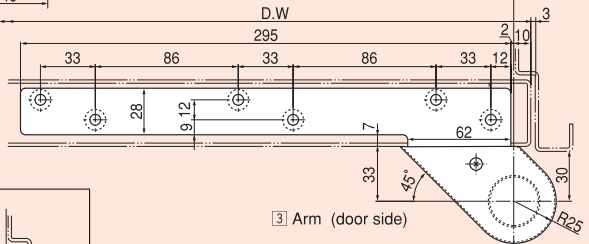

4 Body

### 3CA

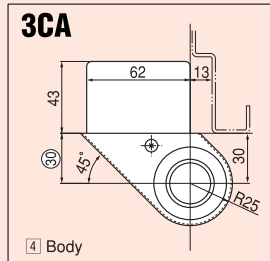

## 3CAD · 3CA

OFFSET HUNG  
(Steel Door)



Pictures show left handed door application.

### MAXIMUM DOOR

D.W×D.H (mm)	1800×3000
DOOR WEIGHT (kg)	300

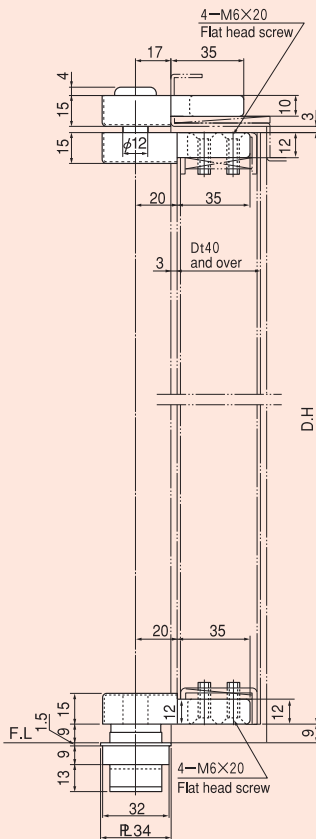

1 Top pivot (upper frame side)

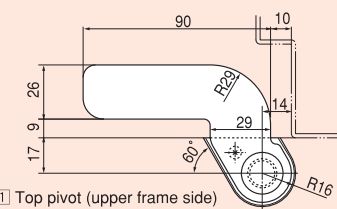

Caution  
Tighten up set screw to prevent loosening.

2 Top pivot (door side)

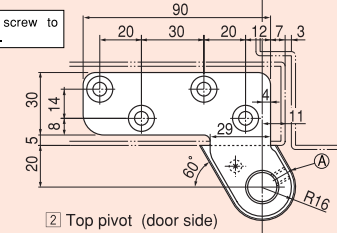

3 Arm (door side)

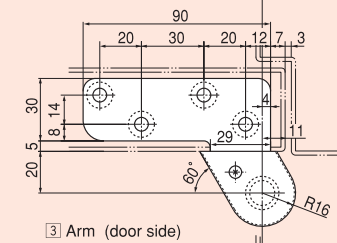

4 Body

## 11-B

OFFSET HUNG  
(Steel Door)



Pictures show left handed door application.

### MAXIMUM DOOR

D.W×D.H (mm)	900×2100
DOOR WEIGHT (kg)	80

# 13B

## OFFSET HUNG (Steel Door)

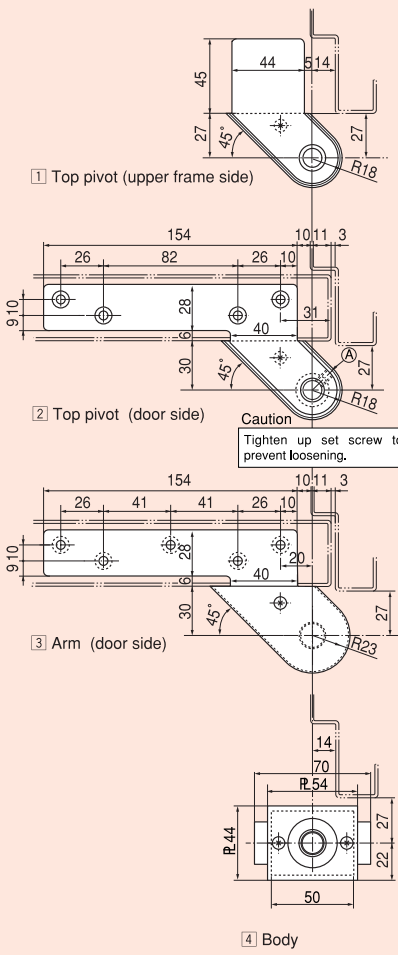
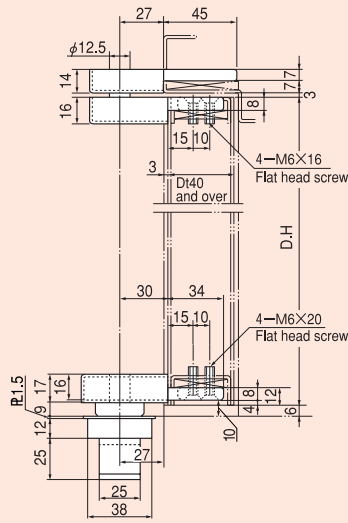

Pictures show left handed door application.

### MAXIMUM DOOR

D.W×D.H (mm)	1050×2200
DOOR WEIGHT (kg)	120

# 2BC·2B

## OFFSET HUNG (Steel Door)

### 2BC

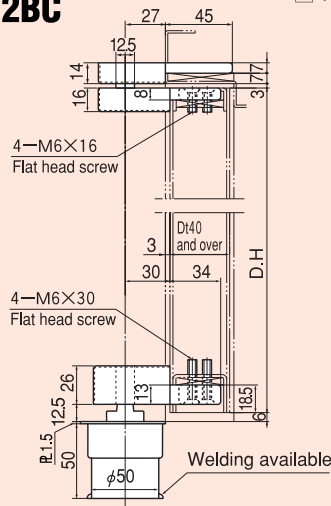

1 Top pivot insert (upper frame).

1 Top pivot (upper frame side)

2 Top pivot (door side)

3 Arm (door side)

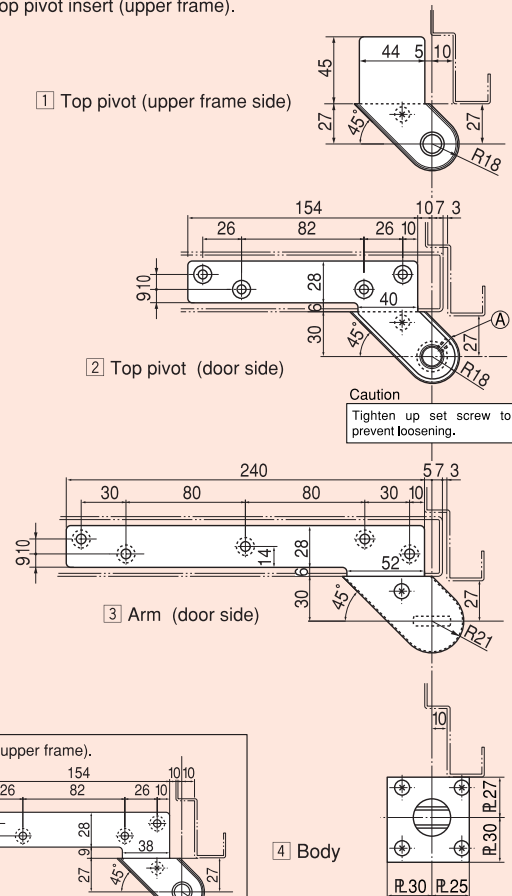

### 2B

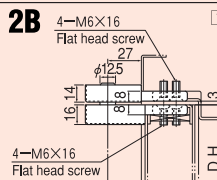

1 Top pivot cut-out (upper frame).

1 Top pivot (upper frame side)

4 Body



Pictures show left handed door application.

### MAXIMUM DOOR

D.W×D.H (mm)	1500×2400
DOOR WEIGHT (kg)	180

### 3BC

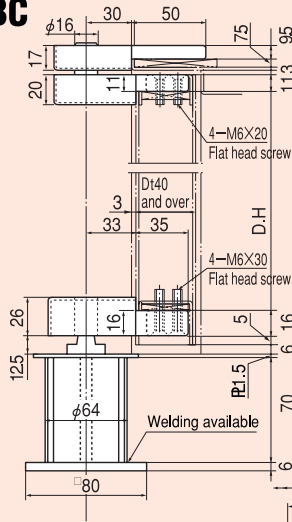

1 Top pivot insert (upper frame).

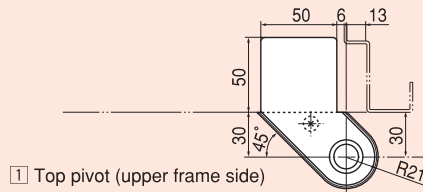

1 Top pivot (upper frame side)

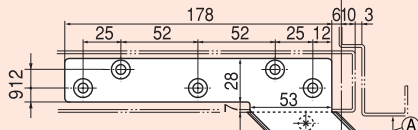

2 Top pivot (door side)  
Caution  
Tighten up set screw to prevent loosening.

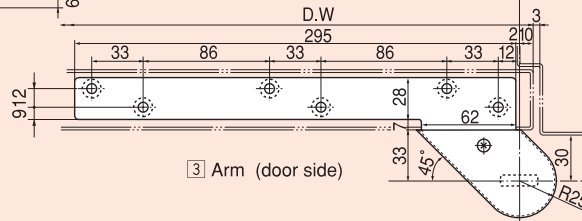

3 Arm (door side)

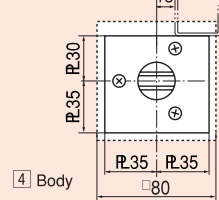

4 Body

### 3B

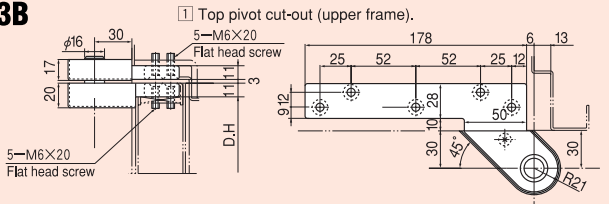

1 Top pivot cut-out (upper frame).

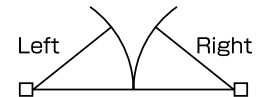
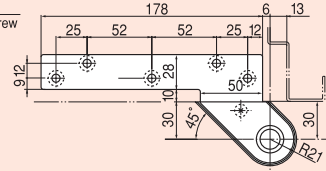

Pictures show left handed door application.

#### MAXIMUM DOOR

D.W×D.H (mm)	1800×3000
DOOR WEIGHT (kg)	300

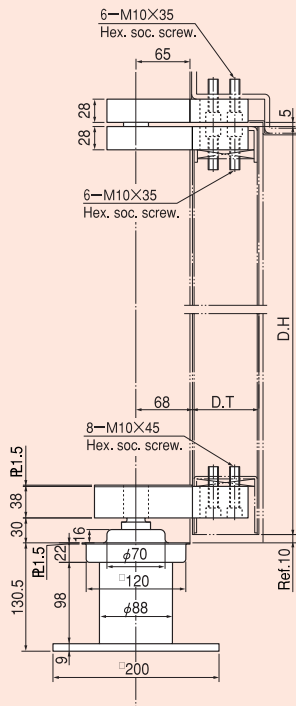

\* Parts supplied to order.  
\* Consult for the delivery time.

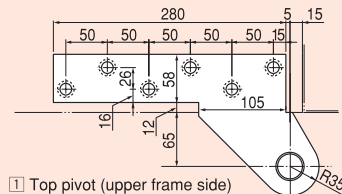

1 Top pivot (upper frame side)

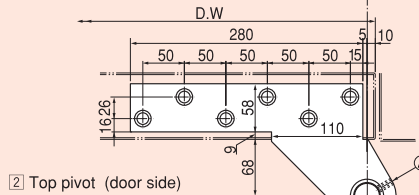

2 Top pivot (door side)

Caution  
Tighten up set screw to prevent loosening.

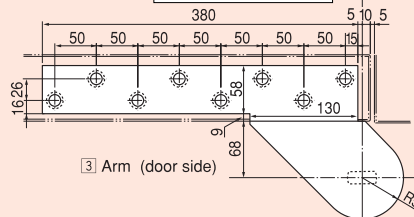

3 Arm (door side)

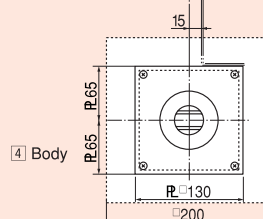

4 Body

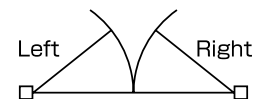

Pictures show left handed door application.

#### MAXIMUM DOOR

D.W×D.H (mm)	4000×5000
DOOR WEIGHT (kg)	1000

# SW-11D

OFFSET HUNG  
(Steel Door)

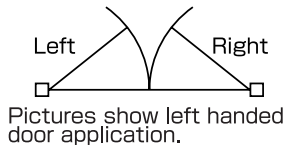

## MAXIMUM DOOR

D.W×D.H (mm)	900×2200
DOOR WEIGHT (kg)	80

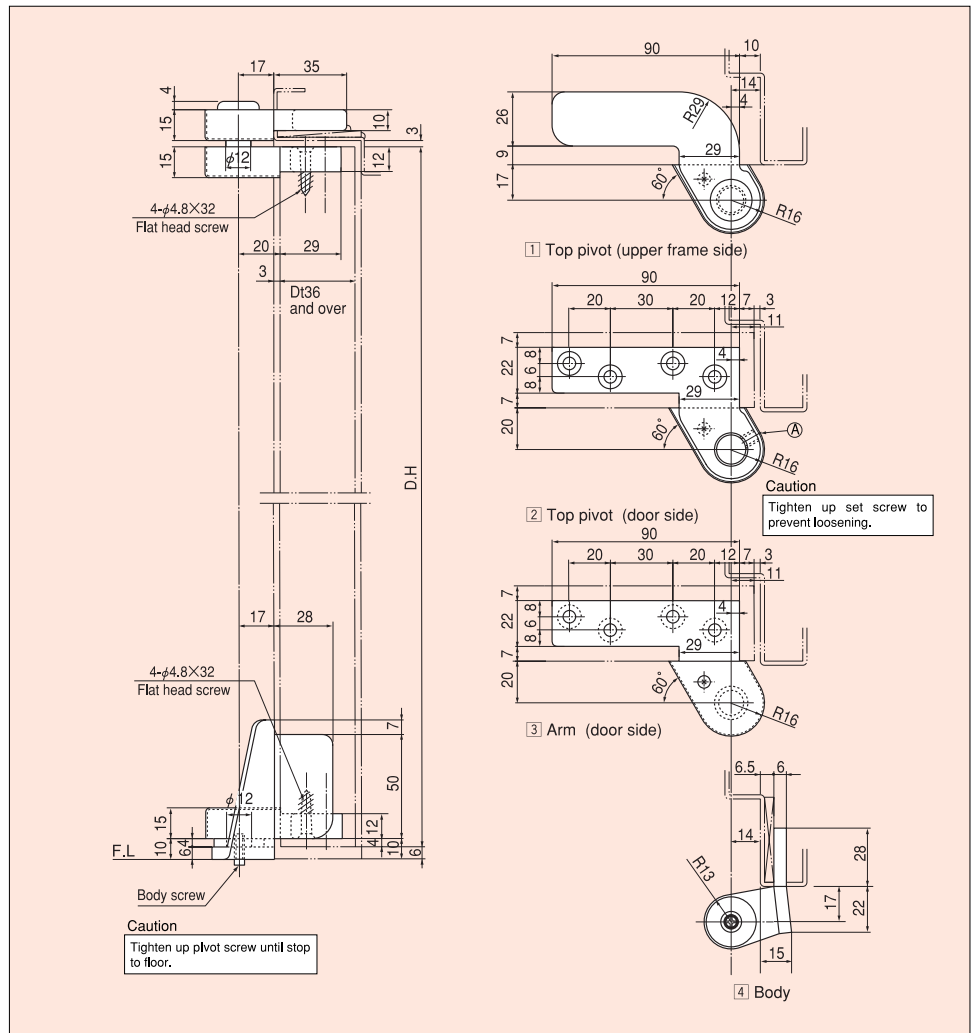

# SW-11CD·SW-11C

OFFSET HUNG  
(Steel Door)

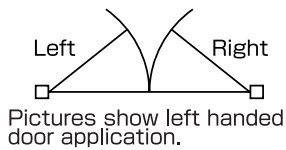

## MAXIMUM DOOR

D.W×D.H (mm)	900×2100
DOOR WEIGHT (kg)	80

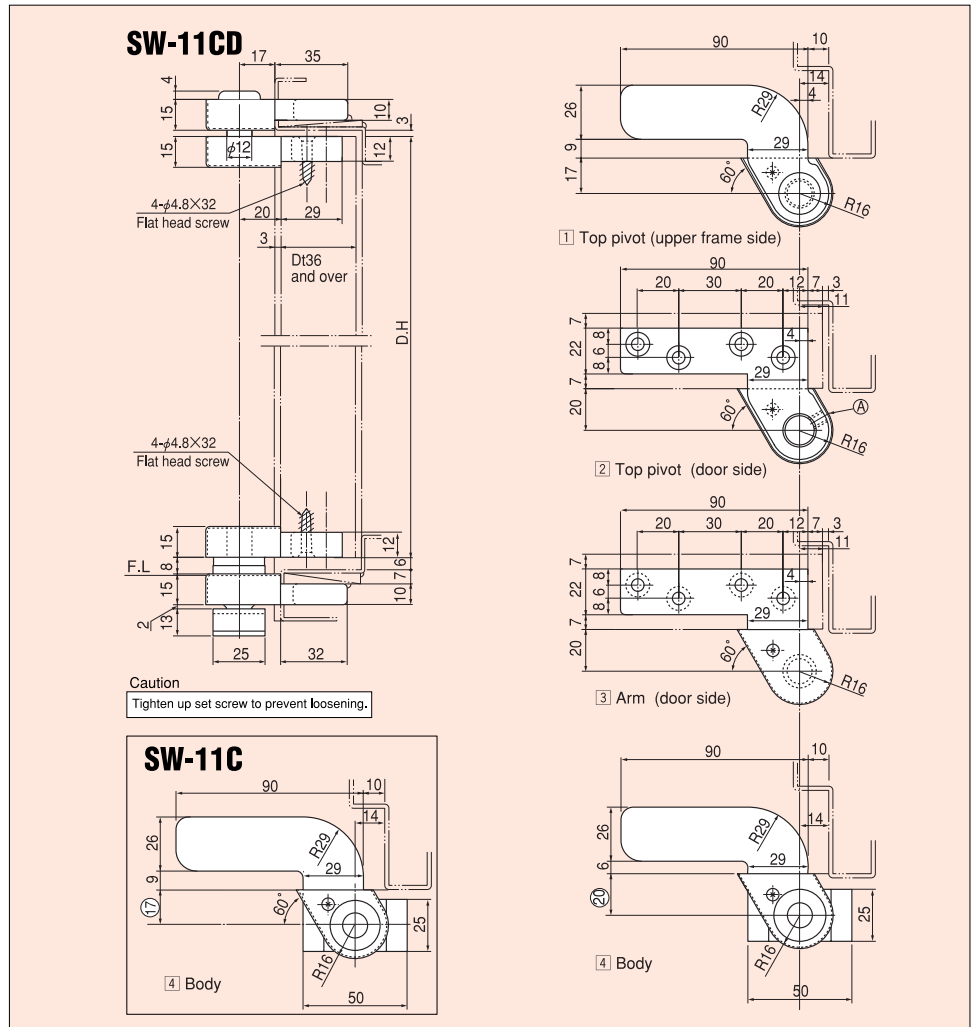

# SW-11B

## OFFSET HUNG (Steel Door)

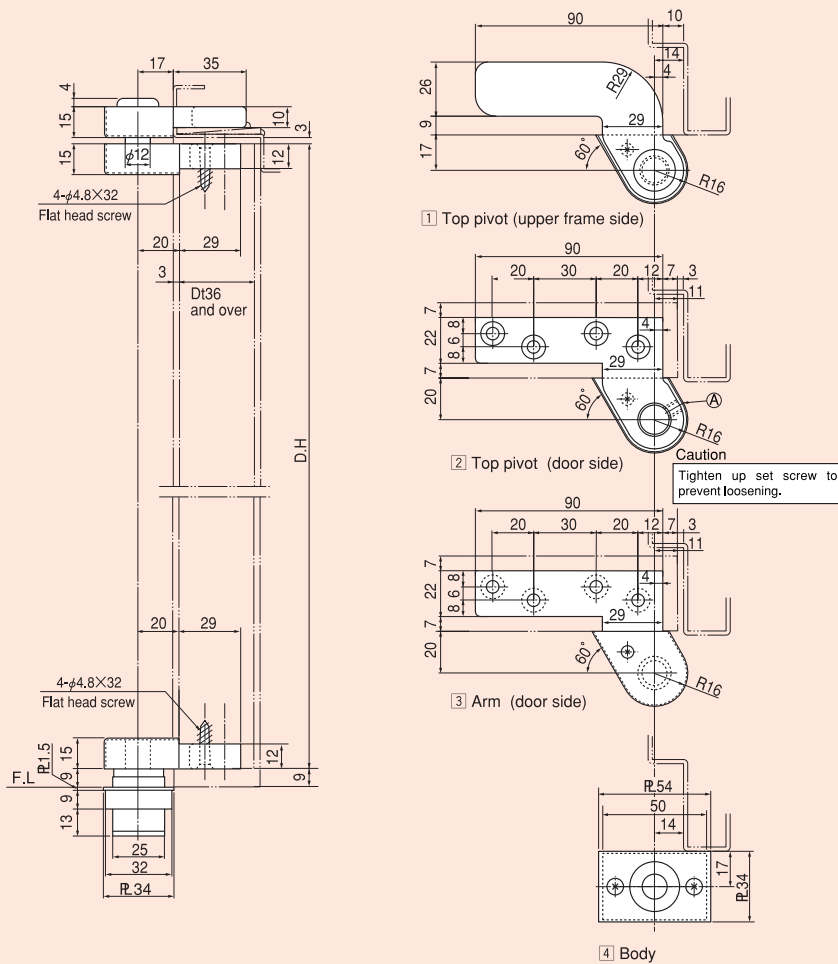

Pictures show left handed door application.

### MAXIMUM DOOR

D.W×D.H (mm)	900×2100
DOOR WEIGHT (kg)	80

1 Top pivot (upper frame side)

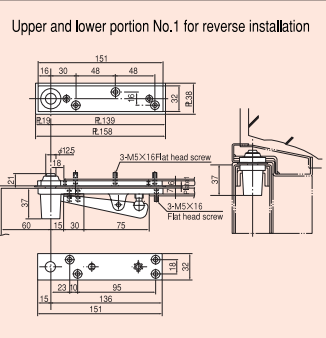
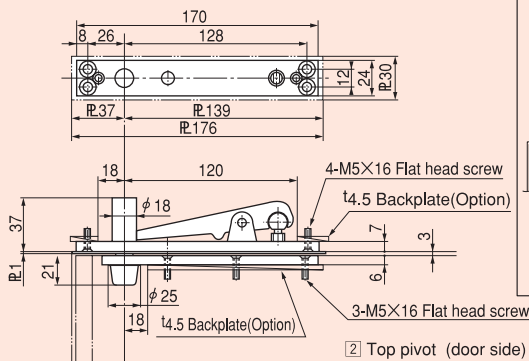

2 Top pivot (door side)

3 Arm (door side)

4 Body

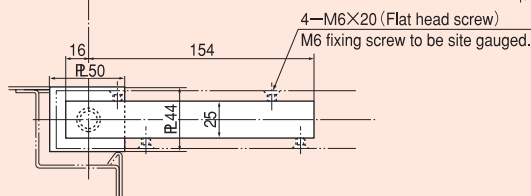

# S-1AF

## CENTER HUNG (Steel Door)

### MAXIMUM DOOR

D.W×D.H (mm)	900×2100
DOOR WEIGHT (kg)	100



# S-1A

## CENTER HUNG

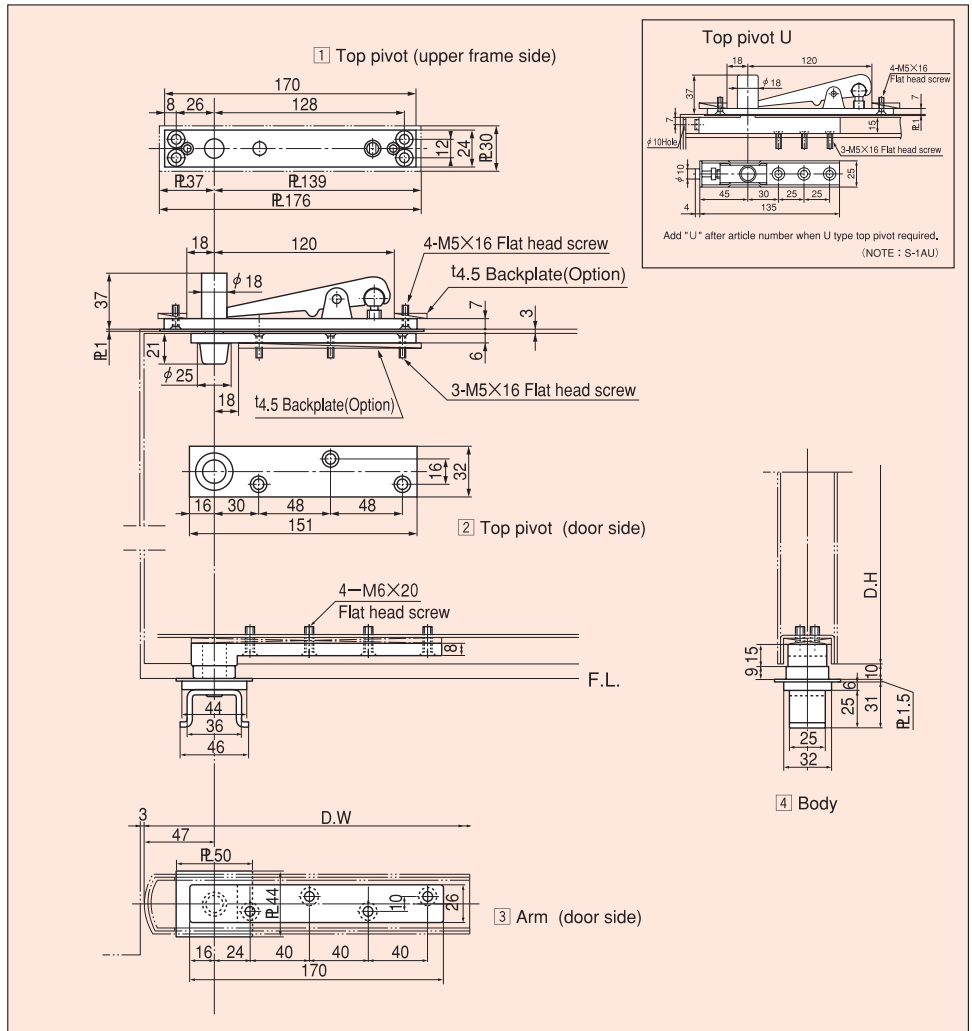

### ■ MAXIMUM DOOR

D.W×D.H (mm)	900×2100
DOOR WEIGHT (kg)	100

# S-2A

## CENTER HUNG

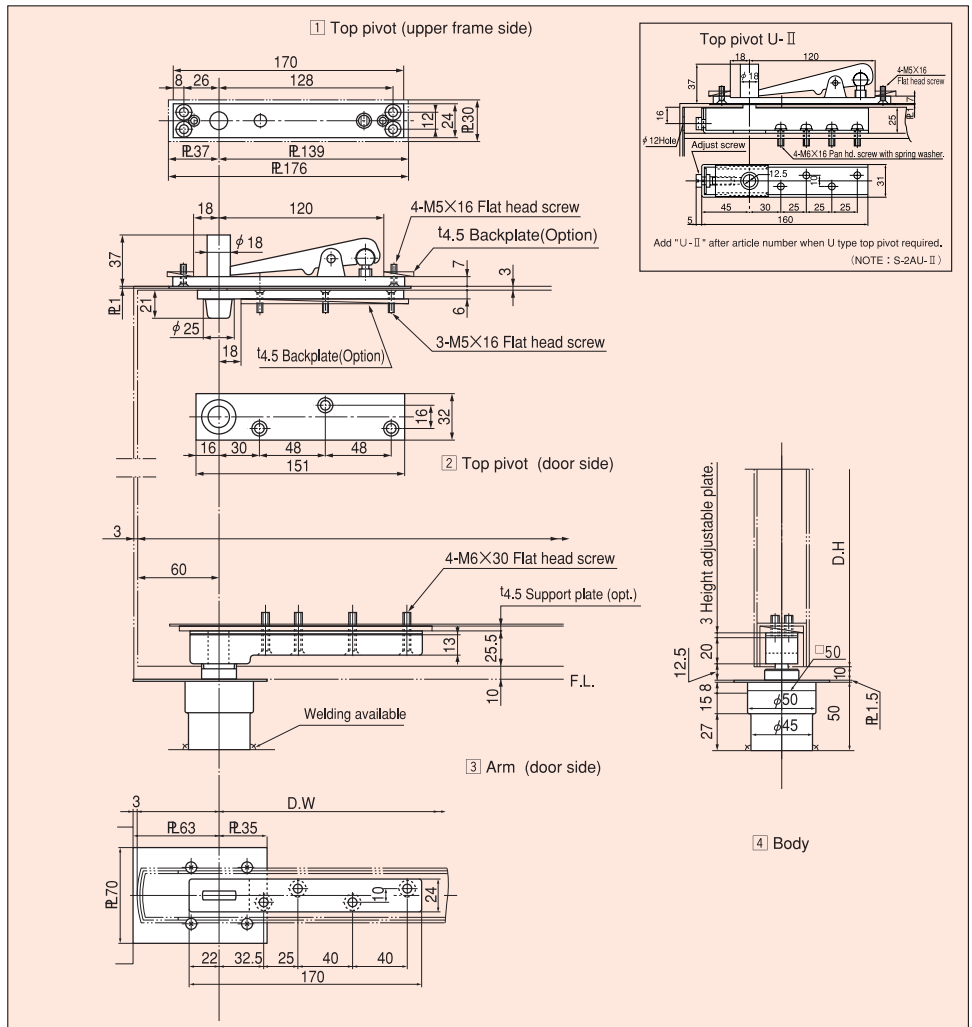

### ■ MAXIMUM DOOR

D.W×D.H (mm)	1500×2400
DOOR WEIGHT (kg)	180

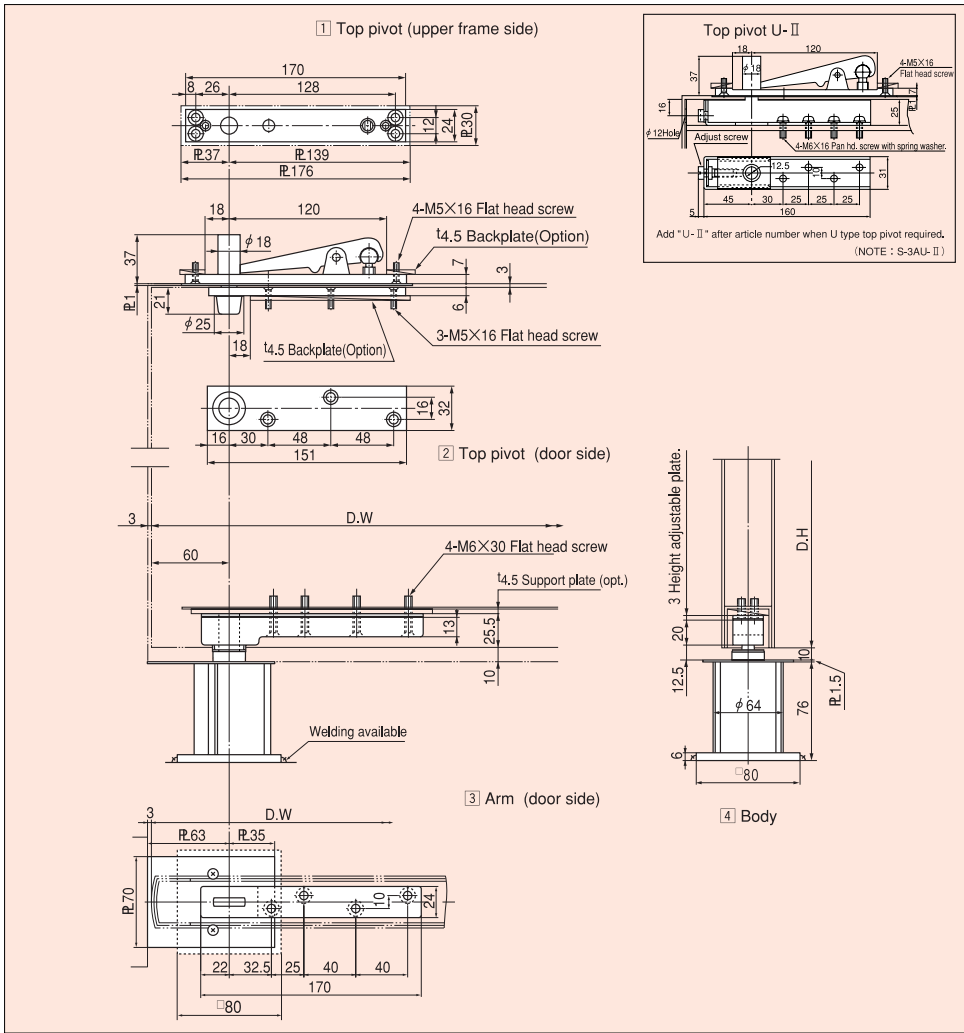

# S-3A

## CENTER HUNG

### MAXIMUM DOOR

D.W×D.H (mm)	1800×3000
DOOR WEIGHT (kg)	300

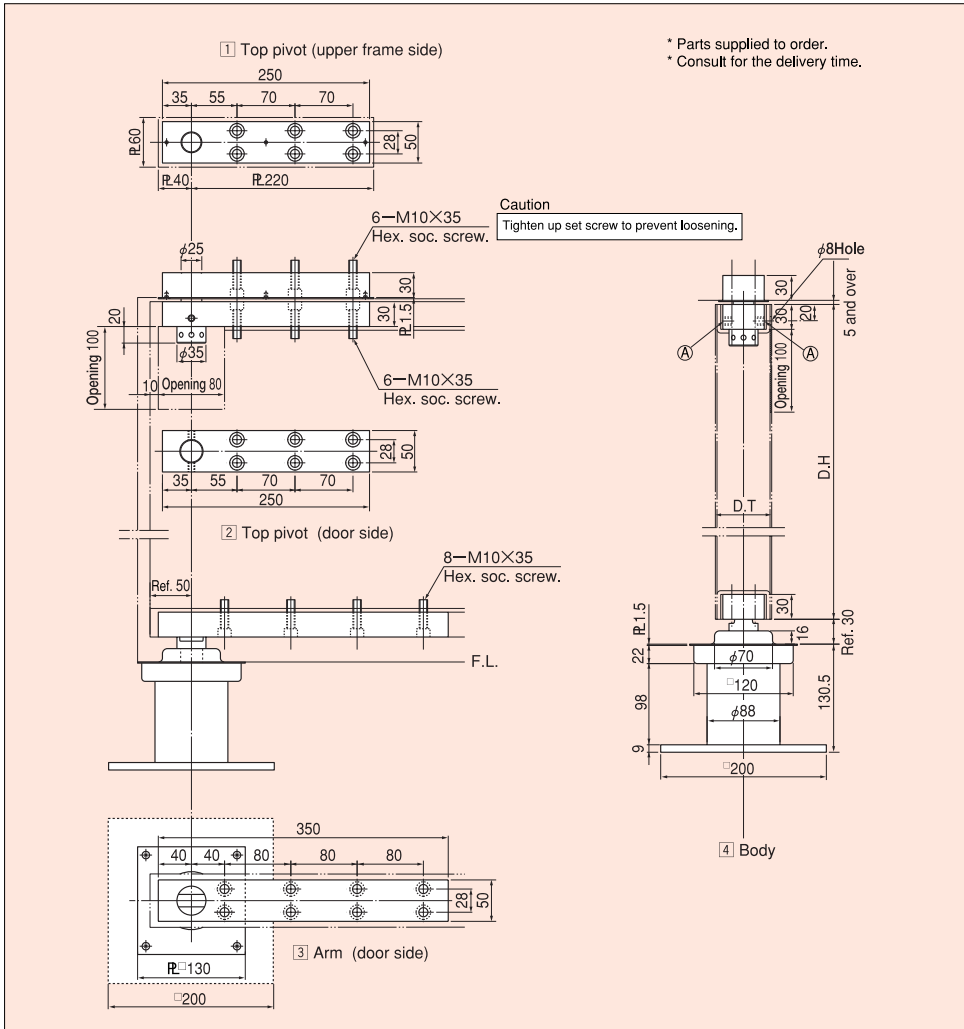

# S-4A

## CENTER HUNG

### MAXIMUM DOOR

D.W×D.H (mm)	4000×5000
DOOR WEIGHT (kg)	1000