

SLIDING DOOR CLOSER

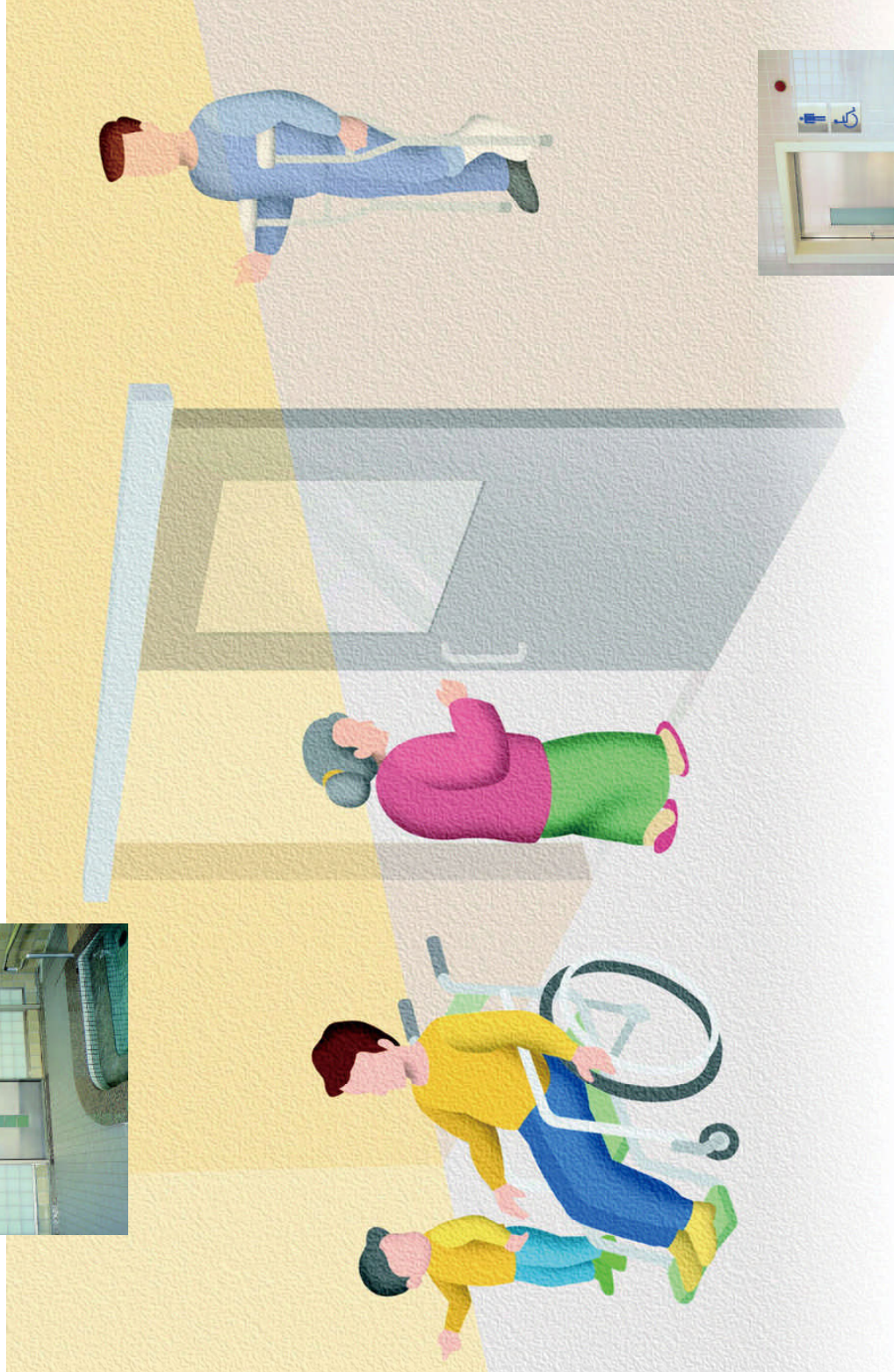

〒531-0076
大阪市北区大淀中1丁目1番30号
梅田スカイビルタワーウエスト12階
Tel: 06-6454-9720
Fax: 06-6454-9727

12th Floor, Umeda Skybuilding Tower West 1-30,
Oyodonaka 1-Chome, Kita-ku Osaka 531-0076 Japan
Phone: 81-(6)-6454-9720
Facsimile: 81-(6)-6454-9727
E-Mail: info@kenwa.co.jp <http://www.kenwa.co.jp>
<http://www.micomautodoor.com>



User-friendly technology

NHN offers a comprehensive range of manual sliding closer system to cater for the widely varying demand of home, work and daily life.

NHN SLIDING CLOSER

C O N T E N T S

● TS Series

FEATURES.....	3
SELECTION CHART, SPECIFICATION.....	4
COMPONENT.....	5
INSTALLATION DIAGRAMS.....	6
LIST OF PARTS.....	7
INSTALLATION MANUAL.....	8~10

● SC Series

FEATURES.....	11
SELECTION CHART, SPECIFICATION.....	12
COMPONENT.....	13~14
INSTALLATION DIAGRAMS.....	15~18

TS-F TYPE



FEATURES

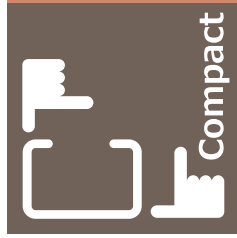

Compact

The whole mechanism is placed in a door frame 150mm high by 70mm deep. This compactness provides greater freedom of installation in limited space.

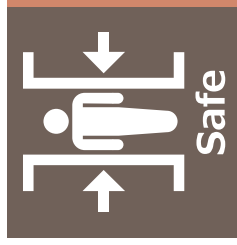

Safe

The newly developed hydraulic gear-pump breaking system controls the door closing with utmost reliability, allowing people to enter and exit safely.



Optional features

Provide advanced functions to meet the additional needs.

• Hold-open function

To hold the door open at the required position. The position and torque can be adjusted easily with a screwdriver.

• Back check

To cushion the slide opening and prevent damage to the door and frame when the door is opened violently.



Easy installation

As all the components are simply mounted on the rail, installation is easy without the need for post-installation readjustment, which assures stable operation.



Easy handling

Opening force as small as 64N(0.65kg) allows the handicapped, the elderly, and children to enter. The opening and closing force can be adjusted within the range of +/-15% with the torque spring.

SELECTION CHART

Door control device	Model	MAX. Door Width	Door weight (kg: max)	Door stroke (mm: max)	Initial opening force (N.m)
Rotary damper	TS-F1-40	2000 mm	40	2,000	10
	TS-F1-80		80		14
Shock absorber	TS-F2-40	2000 mm	40	2,000	10
	TS-F2-80		80		14
Rotary damper & Shock absorber	TS-F3-40	2000 mm	40	2,000	10
	TS-F3-80		80		14

SPECIFICATION

Door closing control	Rotary damper, Shock absorber
Closing speed adjustment	Regular zone, cushioning zone
Closing speed control	By hydraulic braking system
Closing force control	By torque spring
Operating conditions	Temperature : -10 to +50 °C Humidity: 30-85% RH (no harmful air-borne chemicals)

OUTLINE

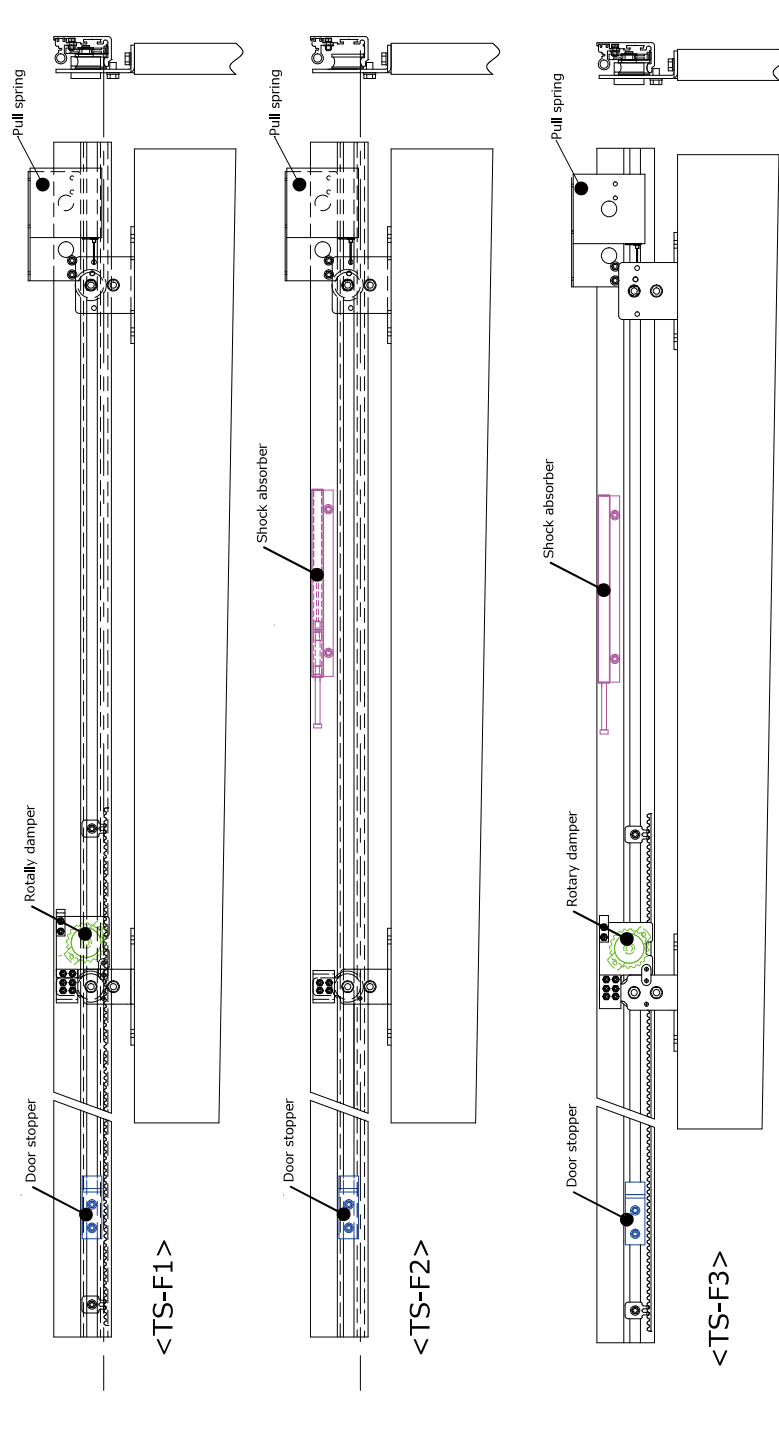

COMPONENT

INSTALLATION DIAGRAMS

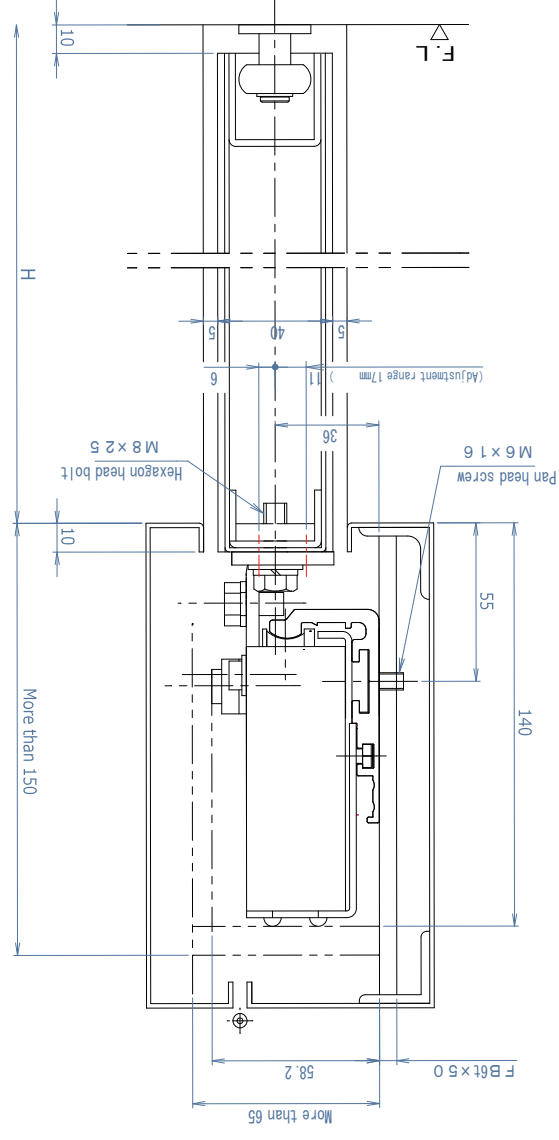
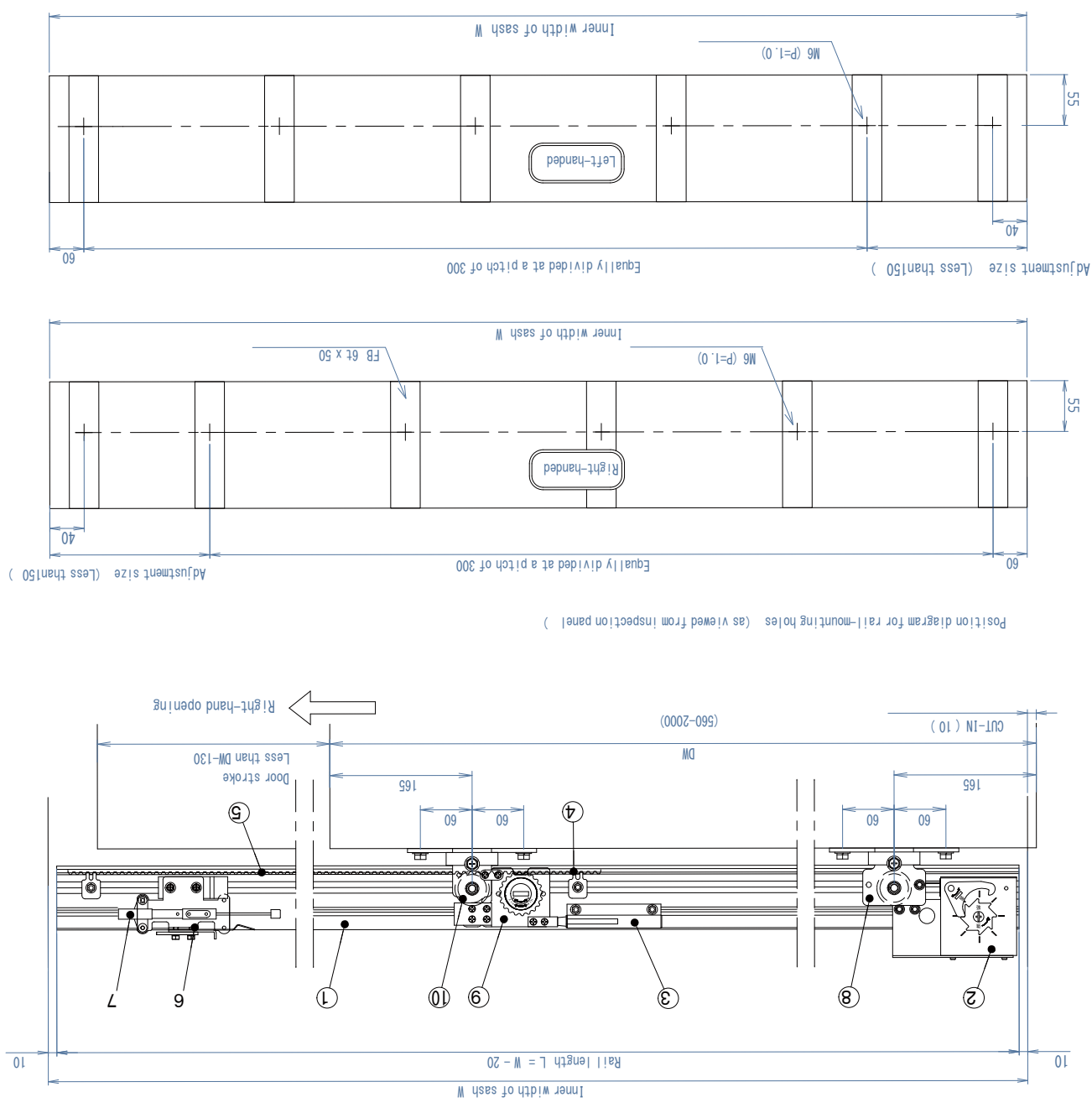
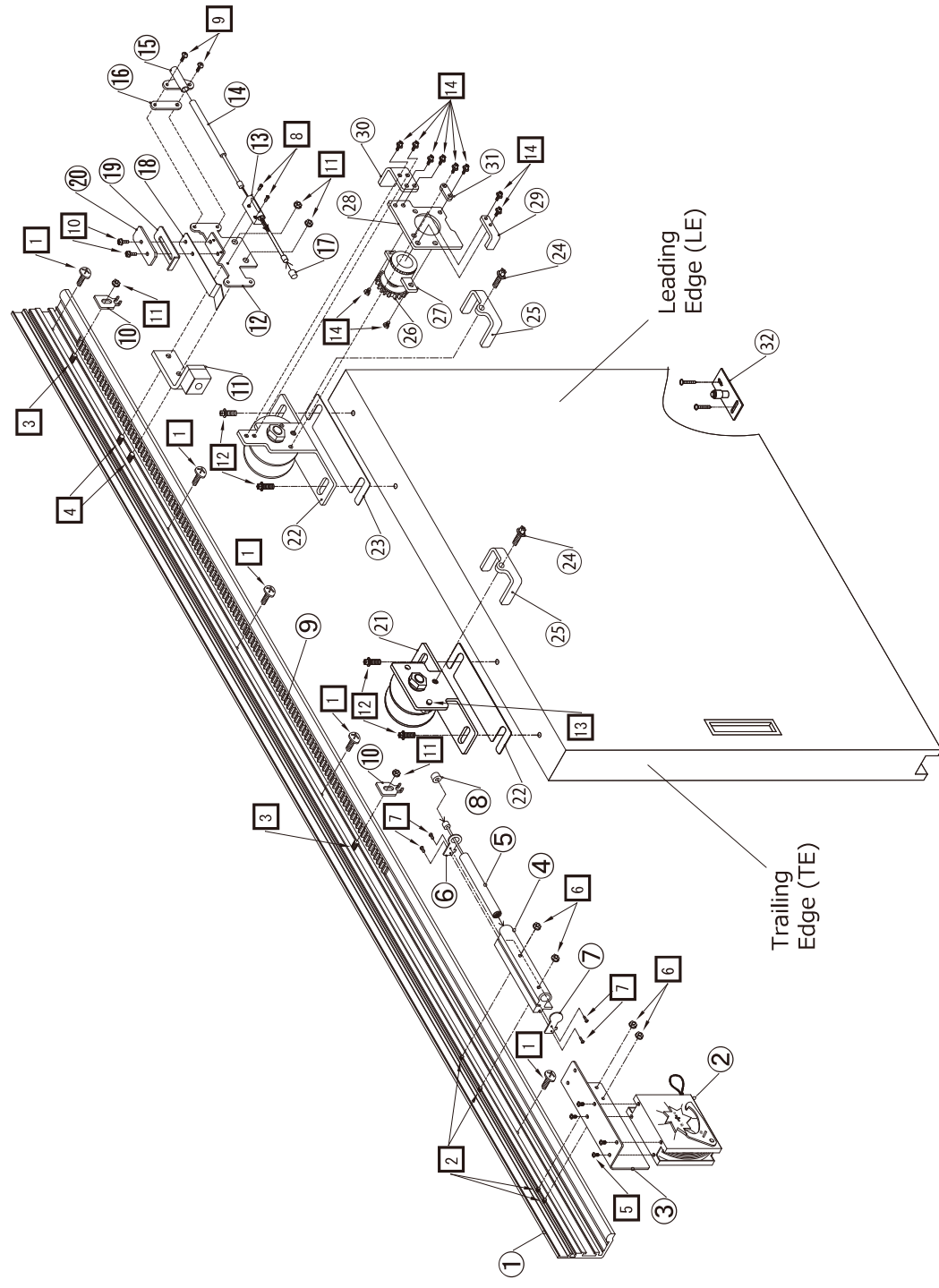

Fasteners List (indicated by boxed numbers)

No.	Fastener	Size	QTY
1	Panhead Screw	M6 x 16	2
2	Hex Bolt	M5 x 12	4
3	Flanged Bolt	M8 x 12	4(2)
4	Square Bolt	M6 x 21	(2)
5	Panhead Screw	M4 x 6	4
6	Flanged Nut	M5	4
7	Panhead Screw	M3 x 8	4
8	Cntrnsink Screw	M4 x 8	(2)
9	Panhead Screw	M4 x 8	(2)
10	Hex Bolt	M5 x 12	(2)
11	Flanged Nut	M6	4(2)
12	Hex Bolt	M8 x 25	4
13	Hex Bolt	M6 x 25	1
14	Hex Bolt	M5 x 10	(10)

No.	Part Name	QTY
17	Silencing Cap	1
18	SC-2S Stop Spring	1
19	Adjustment Plate	1
20	Spacer	1
21	Door Bracket (TE)	1
22	Door Bracket (LE)	1
23	Height adj. shim	1
24	Door Guide Bolt	2
25	Door Guide Brkt	2
26	Pulley (w/1-way bearing)	1
27	Rotary Damper	1
28	Damper Bracket	1
29	Damper Stopper (TE)	1
30	Damper Stopper (LE)	1
31	Door Bracket connector	1
32	Guide Roller	1

No.	Part Name	QTY
1	Guide Rail	1
2	CF Spring	1
3	Spring Bracket	1
4	Damper Guide	1
5	Soft Absorber(blk)	1
6	Cover (w/ hole)	1
7	Cover (w/ hole)	1
8	Cap End	1
9	Timing Belt	1
10	Lock Plate	2
11	Stopper	1
12	Abs. Bracket(LE)	1
13	Abs. Cap	1
14	Soft Absorber(gr)	1
15	Adapter(blk)	1
16	Bracket	1

indicates optional part

* Varies per installation

**Numbers in parenthesis indicate fasteners used to fasten optional parts

LIST OF PARTS

<p>Rotary damper</p> 	<p>Pull spring</p> 	<p>Aluminum rail</p>  <p>(Length : 2200mm, 3100mm, 4000mm)</p>												
<p>Timing Belt</p> 	<p>Hanger (TE)</p> 	<p>Hanger (LE)</p> 												
<p>Hold open device</p> 	<p>Door stopper</p> 	<p>Height adjustment plate</p> 												
<p>Door retention bracket</p> 	<p>Guide roller (option)</p> <table border="1"> <thead> <tr> <th>MODEL</th> <th>D (mm)</th> <th>H (mm)</th> </tr> </thead> <tbody> <tr> <td>LR-20</td> <td>20</td> <td rowspan="4">27</td> </tr> <tr> <td>LR-25</td> <td>25</td> </tr> <tr> <td>LR-30</td> <td>30</td> </tr> <tr> <td>LR-35</td> <td>35</td> </tr> </tbody> </table> <p>Stainless type, H42mm type is available.</p> 	MODEL	D (mm)	H (mm)	LR-20	20	27	LR-25	25	LR-30	30	LR-35	35	<p>Shock absorber (option)</p>  <p>(L type : for DW more than 1400mm)</p>  <p>(S type : for DW less than 1200mm)</p>
MODEL	D (mm)	H (mm)												
LR-20	20	27												
LR-25	25													
LR-30	30													
LR-35	35													
<p>Back-check device (option)</p>  <p>(without hold open device)</p>  <p>(with hold open device)</p>	 <p>LR-OO LR-OON</p> <p>4-Φ4xM4 countersunk screw</p> <p>SUS Hairline finish</p> <p>Guide (plastic)</p> <p>Bearing roller</p>	<p>Floor guide (option)</p>  <p>LRF-30-S (DT28-41mm) LRF-30-L (DT40-53mm)</p> 												

INSTALLATION

① Rail processing

①-1. Cut the rail to a length 20mm shorter than the aluminum sash.
 ①-2. Position the rail to the orientation in the picture below. Cut the right side of the rail for right-opening doors and the left side for left-opening doors.
 ①-3. If the distance from the edge of the rail to the first slotted hole is over 80mm open a $\phi 76.5$ mm hole 30mm from the edge (see drawing below).

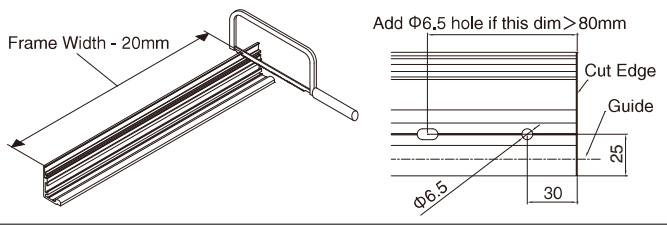

Frame Width - 20mm Add $\phi 6.5$ hole if this dim > 80mm

Cut Edge Guide 20 30 $\phi 6.5$

② Tapped holes for rail installation

②-1. Open M6x1.0 tapped holes in the locations indicated in the drawing below.

- 150mm from the sash nearest to the closing edge of the door
- 65mm from the bottom face of the horizontal beam.
- (for the case of a 10mm gap between the door and frame).

②-2. If the distance between the last hole (opened at 300mm pitch) and the door frame is larger than 150mm, add a $\phi 76.5$ mm hole 30mm from the edge of the rail.

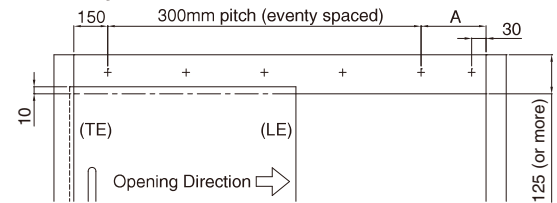

150 300mm pitch (evenly spaced) A 30

10 (TE) (LE) 125 (or more)

Opening Direction →

③ Mounting of pull spring

③-1. Attach constant force spring to its mounting bracket

- Align holes as shown in the picture and fasten four M4x6 panhead screws

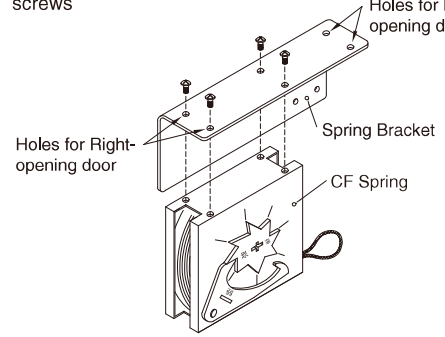

Holes for Right-opening door Spring Bracket CF Spring

Holes for Left-opening door

④ Closing-side shock absorber assembly

※Instructions for standard specifications
 For instructions on assembling the closing-side shock absorber (L-type) please refer to, "Closing-side shock absorber (L-type) Assembly" (separate document)

④-1. Confirm the color on the back of the shock absorber.

- This color is BLACK for the closing-side shock absorber

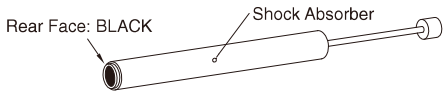

Rear Face: BLACK Shock Absorber

④-2. Insert shock absorber into damper guide and fasten.

- Insert shock absorber from the opening side.
- Properly orient the cover and fasten with M3x8 panhead tapping screws
- Attach the shock absorber's end cap (black)

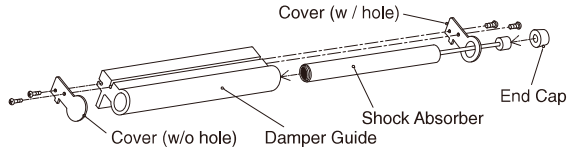

Cover (w / hole) Shock Absorber End Cap

Cover (w/o hole) Damper Guide

⑤ Attach spring and closing-side shock absorber

⑤-1. Slide four M5x12 hexagon head bolts into the upper groove in the rail.
 ⑤-2. Attach spring and shock absorber

- Position the constant force spring 3mm from the edge of the rail and fasten with M5 flange nuts
- Position the shock absorber 152mm from the edge of the rail and fasten with M5 flange nuts

※The shock absorber will be adjusted in a later step.

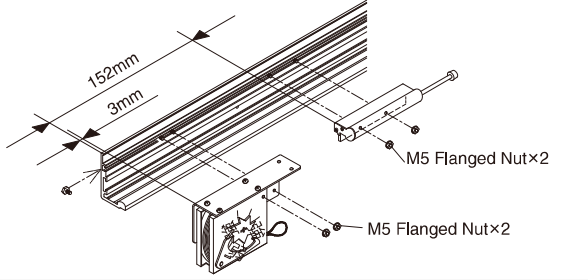

152mm 3mm M5 Flanged Nut×2 M5 Flanged Nut×2

⑥ Opening-side shock absorber assembly

Confirm the color on the back of the shock absorber.

⑥-1. This color is GRAY for the opening-side shock absorber

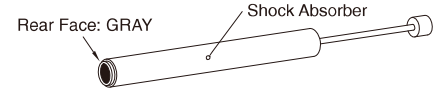

Rear Face: GRAY Shock Absorber

⑥-2. Attach shock absorber to the shock absorber mounting bracket

※Assemble in the order below

- ① Attach the absorber cap with M3x8 panhead screws
- ② Insert shock absorber into the absorber cap
- ③ Attach shock absorber to absorber cap
- ④ Attach absorber spacer and adaptor to absorber bracket using M4x8 panhead screws.
- ⑤ Attach end cap to shock absorber

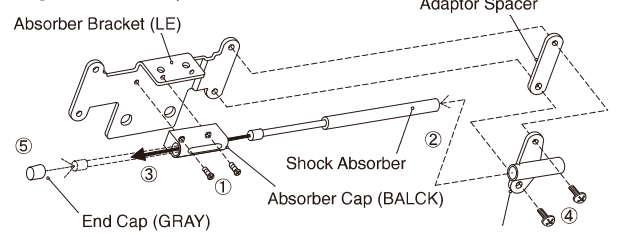

Absorber Bracket (LE) Adaptor Spacer Shock Absorber Absorber Cap (BLACK) End Cap (GRAY)

⑥-3. Attach stopping spring, etc. to absorber bracket (LE)

- As shown in the picture below, attach parts in the following order: absorber bracket, stopping spring, adj. plate, spacer.

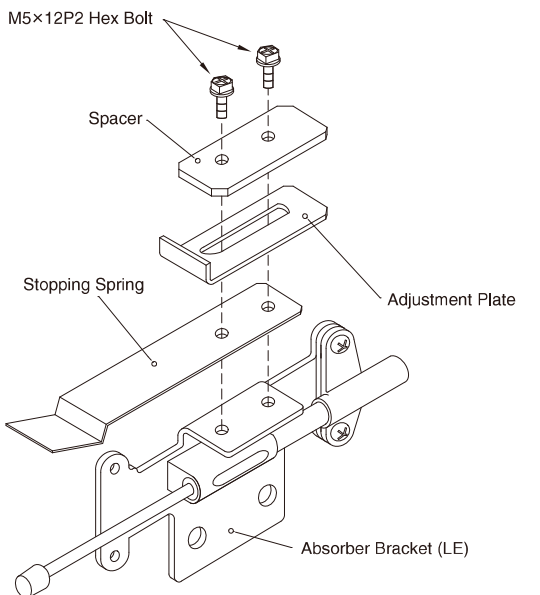

M5×12P2 Hex Bolt Spacer Stopping Spring Adjustment Plate Absorber Bracket (LE)

INSTALLATION

⑦ Attach the opening-side stopper

⑦-1. Slide two M6x21 square head bolt into the guide rail

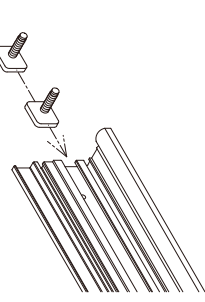

⑦-2. Insert stopper through the square bolts and loosely fasten with M6 nuts.
 ※Do not tighten nuts as the stopper will be adjusted later.
 ※If optional parts are to be installed refer to step OF-3 below.

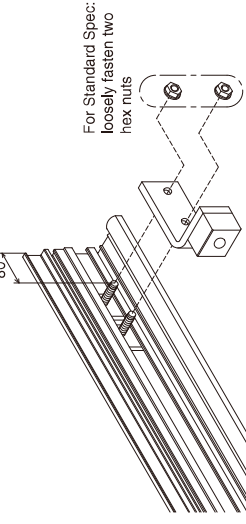

For Standard Spec:
loosely fasten two
hex nuts

⑦-3. For installation of Stop Mechanism (LE) (option)
 ●Align the stop mechanism (assembled in step 6) with the stopper bolts and loosely fasten with M6 nuts.
 ※Do not tighten as this part will be adjusted later

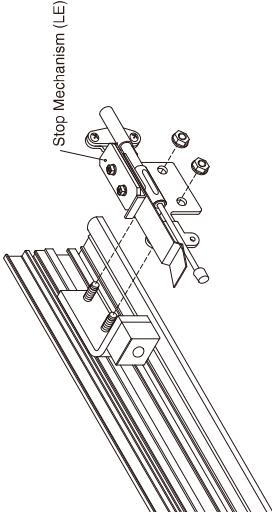

⑧ Cut and attach timing belt

⑧-1. Calculate the length of the timing belt using the equation below and cut

- Belt Length = $0.75L$ (L = length of guide rail)
- Ex.: For rail length, L = 2000, cut the timing belt to $0.75 \times 2000 = 1500\text{mm}$

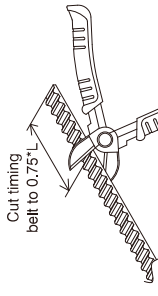

⑧-2. Attach the timing belt to the guide rail
 • Align the right end of the timing belt with the right end of the guide rail and insert the belt into the groove.
 • Insert M8x12 flanged bolt into the bolt groove in the rail, turn and hang flanged bolt and fasten with M8 flanged nuts locking the belt in place.

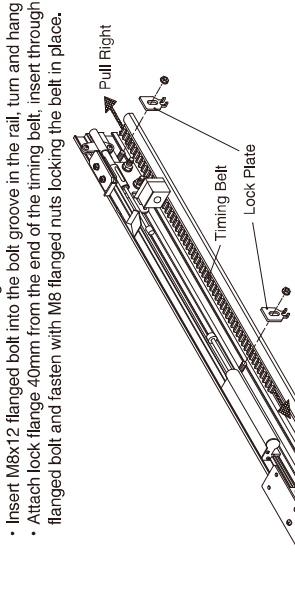

Pull belt to the left until taut

⑨ Mounting the guide rail

⑨-1. Attach the guide rail to the frame

- Position the guide rail 10mm from the vertical frame member
- Confirm that the guide rail is parallel with the floor and fasten with M6x16P2 panhead screws

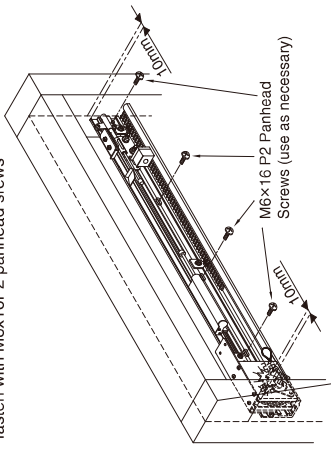

⑩ Door bracket installation

⑩-1. Connect the door with the door brackets using M8 x 60 hexagon head bolts as shown in the drawing below.

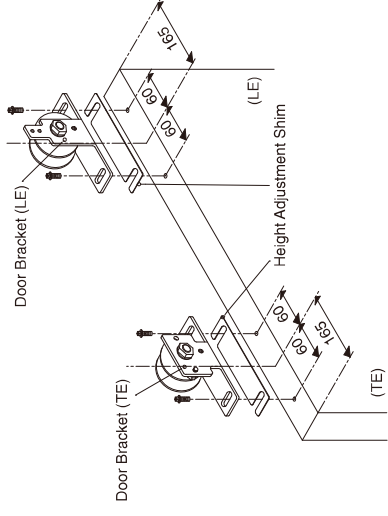

※Be sure that the brackets are mounted parallel with the door and not angled (see example below)

GOOD

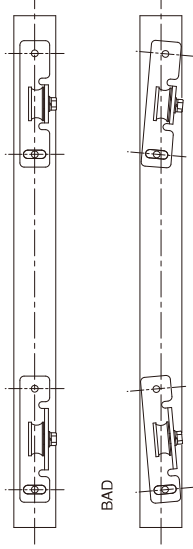

⑪ Hang door

⑪-1. Fix the guide roller (option) to the floor.

- ※Part may vary with specifications, such as door size.

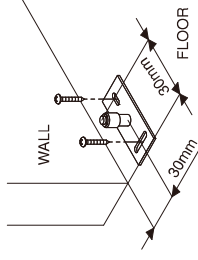

⑪-2. Wipe the roller guide with a dry cloth.

⑪-3. Insert the roller guide between the top of the door and the roller and hang door.

- Operate the door by hand and confirm that the door moves smoothly and is level with the floor.
- ※If the door's motion is not smooth or the door makes noise during operation, adjust the position of the door bracket.

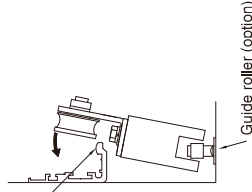

Guide roller (option)

INSTALLATION

⑫ Connect pull spring

⑫-1. Fasten a hexagon head bolt to the leading door bracket.

- Fasten the bolt so that the head of the bolt is on the same side as the roller

⑫-2. Hang the wire loop on the end of the screw fastened in step ⑫-1

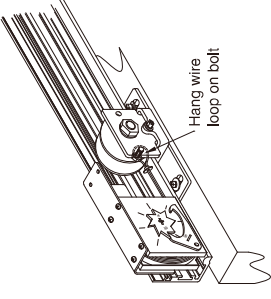

⑬ Mounting of rotary damper

⑬-1. Attach the rotary damper to the door bracket (LE)

- ※Assemble in the following order

① Confirm the pulley's one-way bearing direction (indicated on the label)
 ② Attach plastic washer, pulley, plastic washer, set pin to the rotary damper
 ※Orient the pulley property (check the pulley's label)

③ Turn the pulley while sliding it onto the shaft of the rotary damper
 ④ Attach the rotary damper (assembled in the previous step) to the damper bracket using two M5x10 hex bolts.

⑤ Attach the damper bracket (from the previous step), to the door bracket connector, and damper stopper to the door bracket (LE) using two M5x10 P3 hex bolts.

- ※Ensure that the pulley and timing belt are properly mated during installation

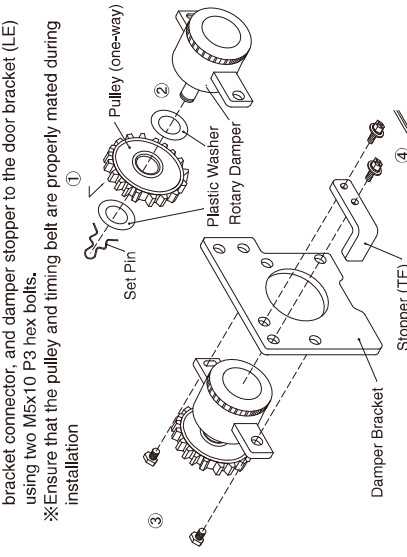

⑬-2. Attach the damper stopper to the door bracket (LE)

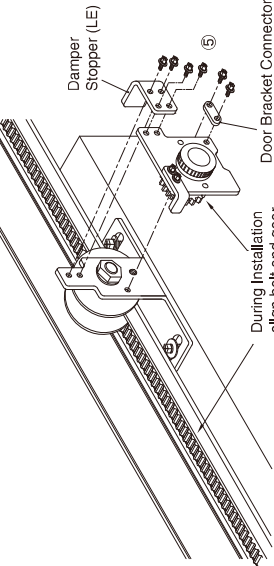

⑭ Door guide bracket (bolt) installation

⑭-1. Attach the door guide bolt and door guide bracket (option)

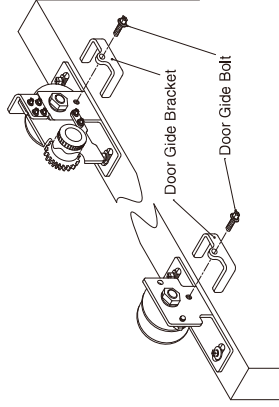

⑮ Back-check device position/force adjustment

⑮-1. Fully open the door, move the stopper so it touches the door and fasten

- If there is clearance between the door and the frame in the fully open position, consult with the customer before adjusting the stopper

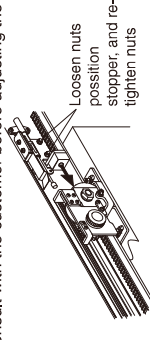

⑮-2. The stop mechanism can be set to three different strength settings

- ※Consult with the customer before adjusting

Slightly loosen bolts

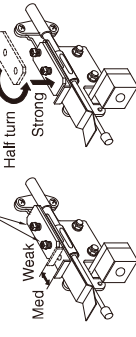

⑯ Spring force adjustment

⑯-1. Adjust the spring force

- ※Position the door in the fully-open position before adjusting to prevent damage to the spring.

● To raise the spring force

- Use a screwdriver to turn the sprocket in the appropriate direction as indicated on the label.

● To lower the spring force

- Move the latch by hand so the sprocket rotates in the opposite direction

• Move the latch by hand so the sprocket rotates in the opposite direction

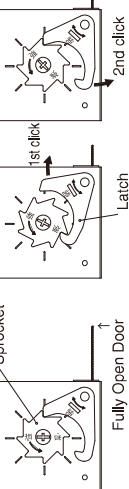

Fully Open Door

Spring strength per # of sprocket revolutions

Strength	Serial	HDZ - 340	HDZ - 380
Weak	320g (7 rev)	700g (3 rev)	760g (2 rev)
	360g (3 rev)	760g (2 rev)	800g (1 rev)
	380g (1 rev)	720g (1 rev)	800g (0 rev)
Standard	400g (0 rev)	860g (1 rev)	860g (1 rev)
	420g (1 rev)	860g (1 rev)	880g (3 rev)
	440g (3 rev)	880g (3 rev)	900g (5 rev)
Strong	480g (8 rev)	12 rev	8 rev

⑰ Closing-side shock absorber adjustment

⑰-1. Adjust the position of the closing-side shock absorber

- Move the door to the fully-open position
- Loosen the nuts on the closing-side shock absorber
- Position the leading door bracket so it is touching the shock absorber's rod in the fully depressed state, and re-tighten the nuts
- Open the door by hand and release. Check the effectiveness of the brake

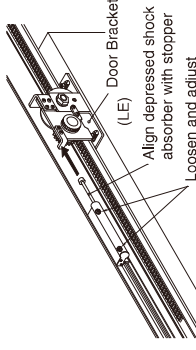

⑱ Closing speed adjustment

⑱-1. Using the dial on the rotary damper (on the trailing door bracket), adjust the closing speed to the standard setting.

- Adjust the dial so that the closing time from the door's fully open position to fully closed position is between six to eight seconds.

※Double check the instructions while performing adjustments from steps ⑮ through ⑱

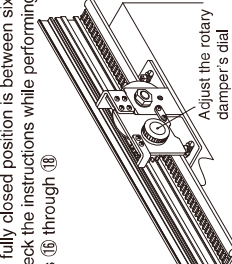

SC TYPE



FEATURES

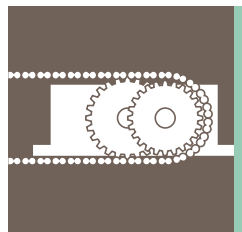

NHN's technology

The closing cycle is controlled by the hydraulic door closer engineered by the NHN's superior technologies accumulated over the extended periods of time, assuring stable and safe operation.

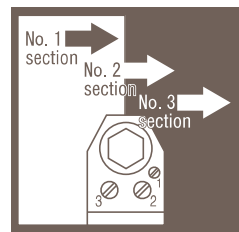

Three sectional closing speed adjustment

Each sectional speed can be regulated by its own speed adjustment valve on the door closer, permitting safe traffic.

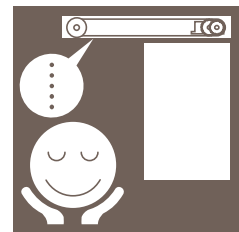

Quiet operation

Reinforced resin rollers and aluminum rail eliminate annoying noise. Suitable for installation at hospitals, libraries, schools, and wherever quietness is required.

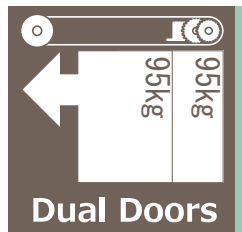

Operates dual doors of up to 190kg

Operates as heavy as 190kg, dual doors (each door up to 95kg.)

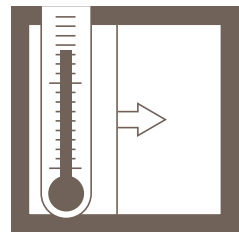

Stable operation

Non-critical thermostatic valves provide constant closing speed even under extreme temperatures.



Optional features

Provide advanced functions to meet the additional needs.

• Hold-open function

To hold the door open at the required position. The position can be adjusted easily with a screwdriver.

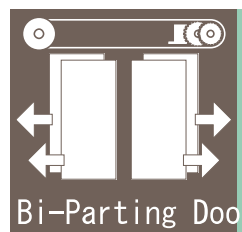

Operates interlocked bi-parting doors

SC TYPE

	Type of installation	Model name	Door width x height (mm: max)	Door weight (kg: max)	Door stroke (mm: max)	Initial opening force (N .m)
General-purpose doors	Flat bar	SCF-20	1,400×2,200	20	1,400	13.7
		SCF-30		30		17.6
		SCF-50		50		21.6
		SCF-80		80		27.4
		SCF-80U	2,000×2,200	100		34.3
		SCF-120	2,000×2,500	120		37.2
		SCF-200	200	44.1		
		SCF-200U	2,400×2,500	250		53.9
	Surface-mounted (with a cover)	SCA-20	1,400×2,200	20	1,400	13.7
		SCA-30		30		17.6
		SCA-50		50		21.6
		SCA-80		80		27.4
Built-in (in a sash)	SCB-30	1,400×2,200	30	1,400	17.6	
	SCB-50		50		21.6	
	SCB-80		80		27.4	
Interlocked parting doors	Flat bar	SCF-50D	1,200×2,200	25×2	1,200	24.5
		SCF-80D		40×2		32.3
	Surface-mounted (with a cover)	SCA-50D		25×2		24.5
		SCA-80D		40×2		32.3
	Built-in (in a sash)	SCB-50D		25×2		24.5
		SCB-80D		40×2		32.3
Fire doors	Flat bar	SCF-50F	1,400×2,200	50	1,400	21.6
		SCF-80F		80		27.4
		SCF-80UF	2,000×2,200	100	2,000	34.3
		SCF-120F		120		37.2
		SCF-200F	2,000×2,500	200	2,000	44.1
		SCF-200UF		250		53.9
Dual doors	Flat bar	SCF-30-2SD	800×2,200	15×2	1,500	19.6
		SCF-50-2SD		25×2		23.5
		SCF-80-2SD	1,000×2,200	40×2	1,900	31.4
		SCF-80U-2SD		50×2		36.3
		SCF-120-2SD	1,200×2,500	60×2	2,300	41.2
		SCF-200-2SD		80×2		47.0
SCF-200U-2SD	1,400×2,500	95×2	2,700	57.8		

Note 1: Custom-made specifications are available upon request.
 Note 2: Manual opening/closing system is available for all models.

SPECIFICATION

< Hydraulic Type >

Item	Description
Door closing control	By hydraulic door closer
Closing speed adjustment	Delayed zone, Regular zone, cushioning zone
Closing speed control	By hydraulic door closer
Operating conditions	Temperature: -10° to +50°C Humidit: 30 - 85%RH (no harmful air-borne chemicals)

COMPONENT (SCB, for single sliding door)

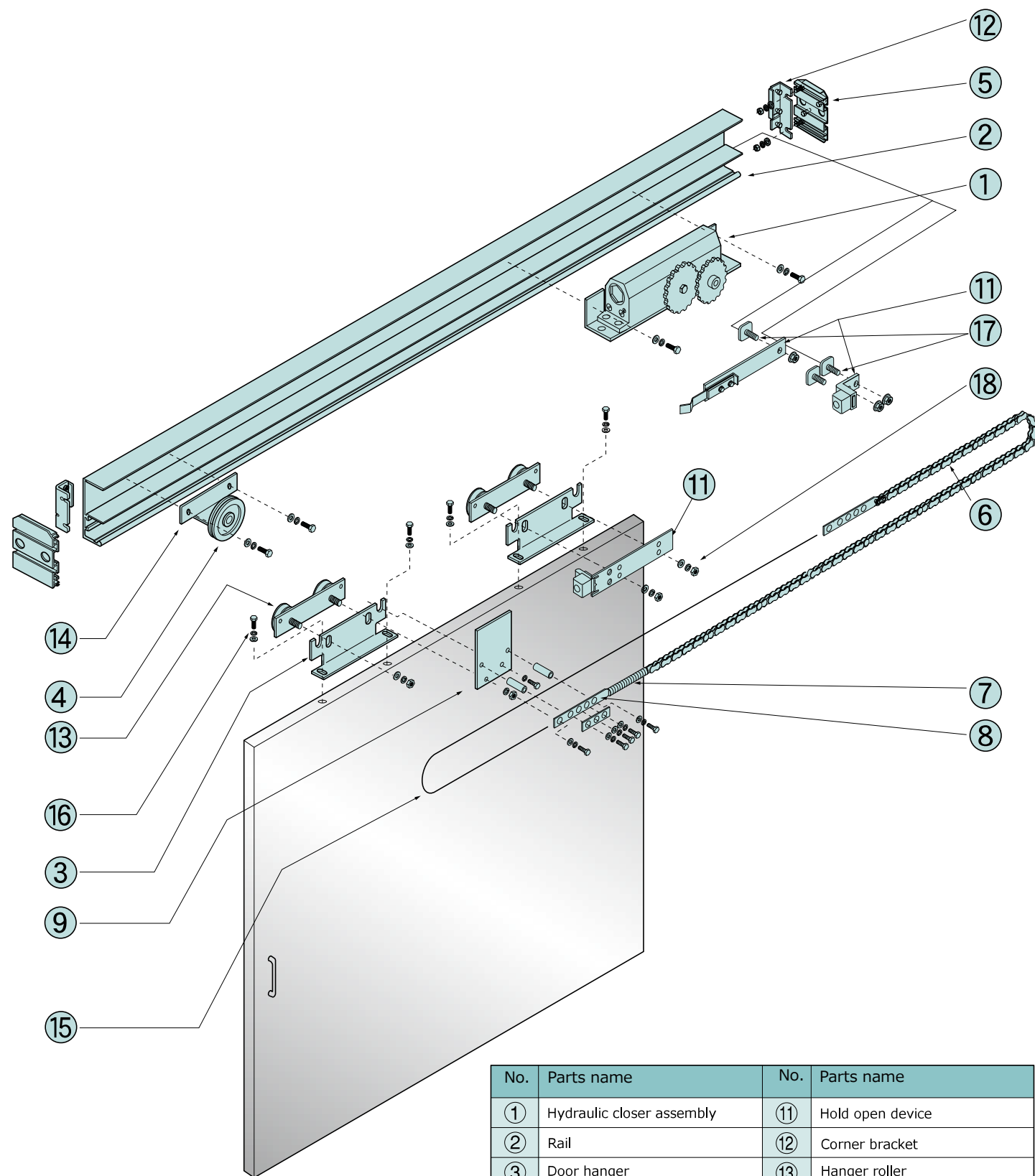

No.	Parts name	No.	Parts name
①	Hydraulic closer assembly	⑪	Hold open device
②	Rail	⑫	Corner bracket
③	Door hanger	⑬	Hanger roller
④	Idler pulley	⑭	Pulley bracket
⑤	Corner piece	⑮	Wire
⑥	Roller chain	⑯	Bolt M8 x 25 (with washer)
⑦	Chain spring	⑰	Bolt M8 x 19
⑧	Wire-chain connector	⑱	Hex.nut M8 (with washer)
⑨	Wire chain bracket		

COMPONENT (SCFN-2S, for double sliding door)

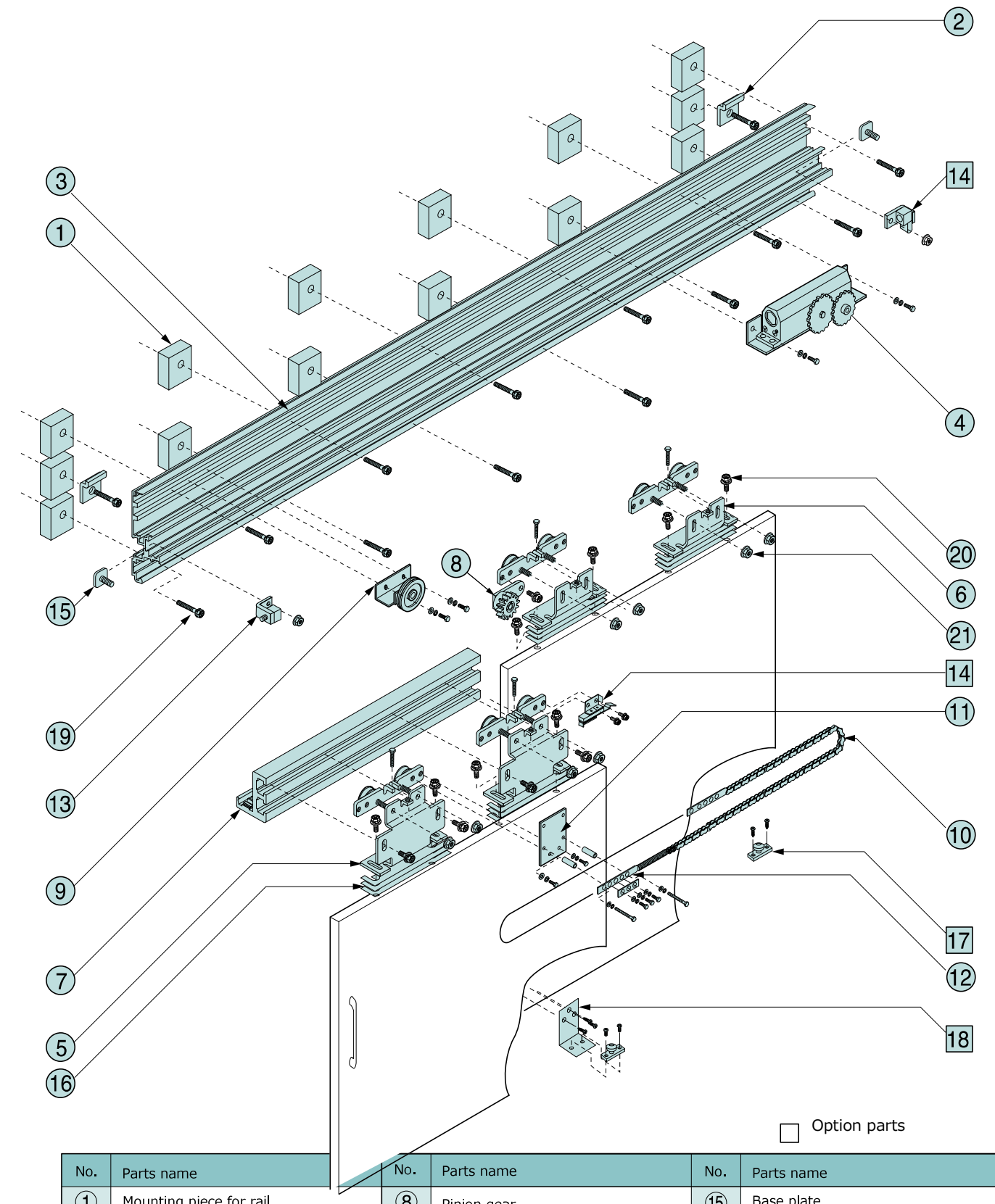

No.	Parts name	No.	Parts name	No.	Parts name
①	Mounting piece for rail	⑧	Pinion gear	⑮	Base plate
②	Rail connecting bracket	⑨	Idler pulley	⑯	Height adjustment plate
③	Rail	⑩	Wire chain	⑰	Guide roller
④	Hydraulic closer assembly	⑪	Wire chain connector	⑱	Bolt M8 x 35
⑤	Hanger bracket (for high speed door)	⑫	Wire chain bracket	⑳	Bolt M8 x 25
⑥	Hanger bracket (for low speed door)	⑬	Stopper	㉑	Hex. nut M8
⑦	Rack holder	⑭	Hold open device		

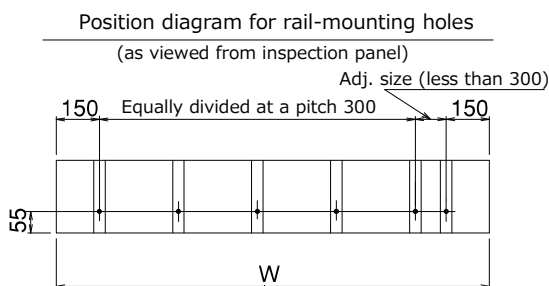
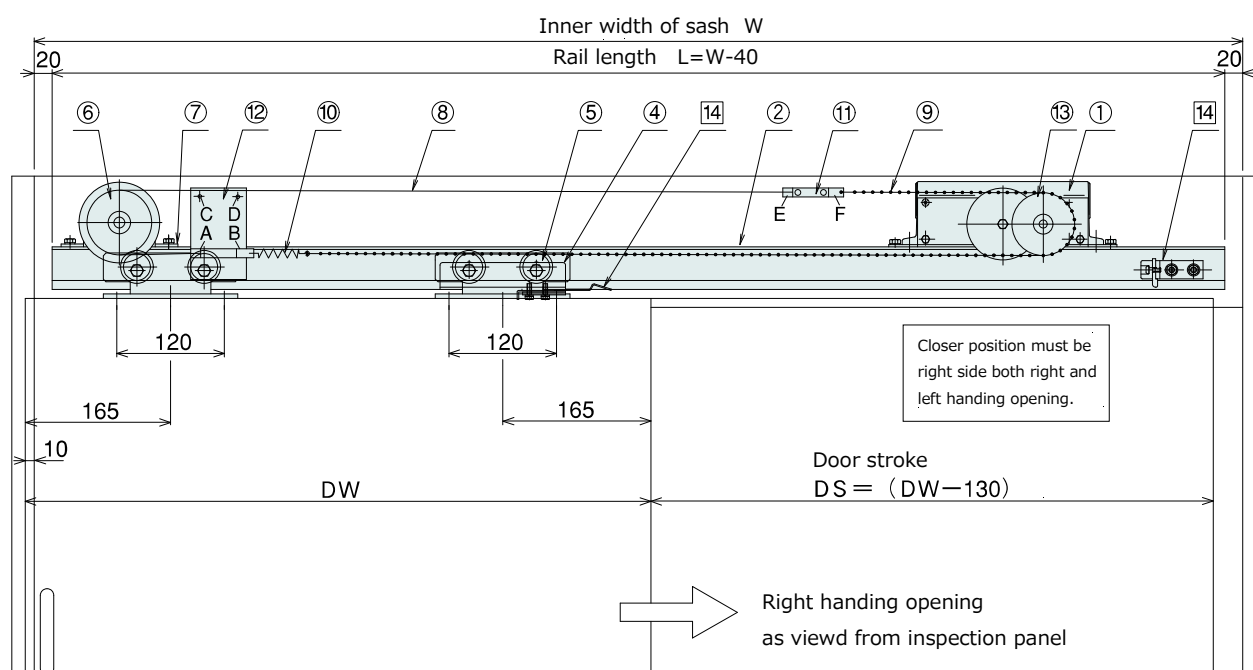
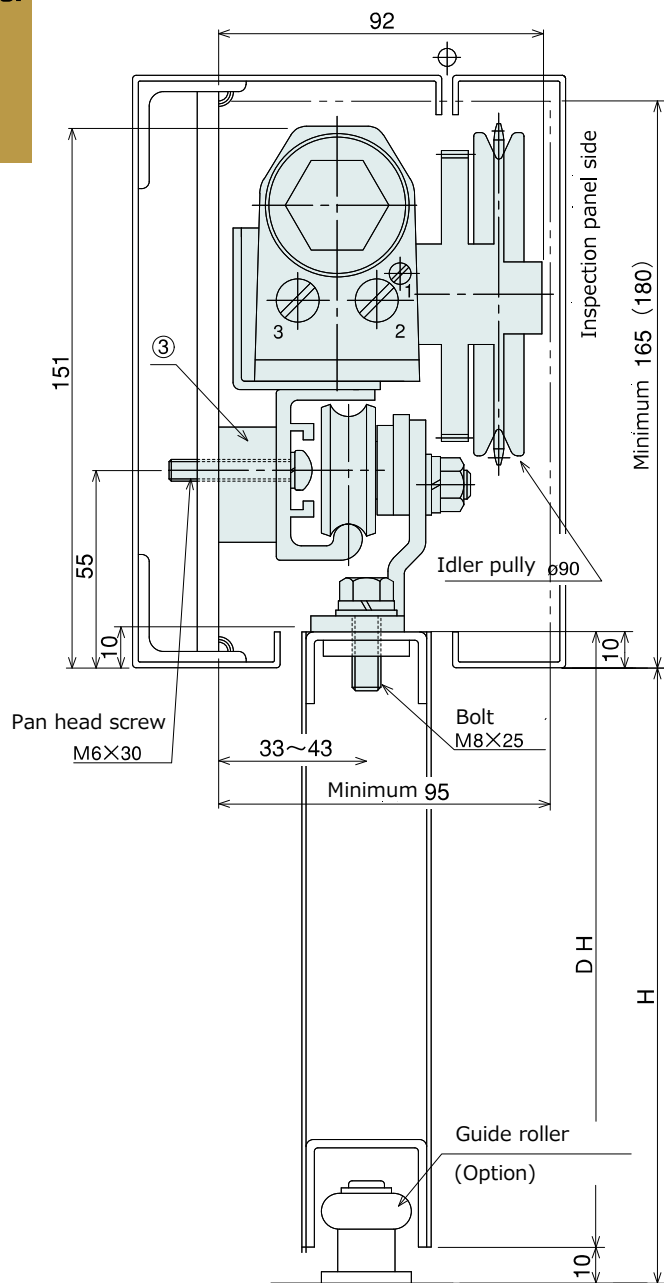

①	Hydraulic closer assembly	Assy	1	With chain sprocket
②	Rail	Aluminum	1	
③	Rail mounting piece	Plastic	(9)	Door height adjustable
④	Door hanger	SS400	2	With ball bearing
⑤	Hanger roller	Plastic	4	With ball bearing
⑥	Idler pulley	Plastic	1	
⑦	Pully bracket	SS400	1	
⑧	Wire (2mm)	Stainless	1	
⑨	Roller chain	JIS RS-25	1	
⑩	Chain spring	SWPB	1	
⑪	Wire chain connector	SS400	2	
⑫	Wire chain bracket	SS400	1	
⑬	Chain sprocket	SS400	1	
⑭	Hold open device	Assy	1	Option

This diagrams shows right-hand opening.
 To change left-hand opening,
 1.) Take out screw "A" & "B" of wire-chain bracket (⑫).
 2.) Close door at right side.
 3.) Wire chain connector(⑪) "E" & "F" connect to "C" & "D" of wire chain bracket(⑫)

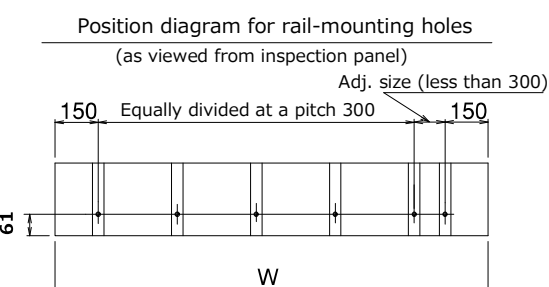
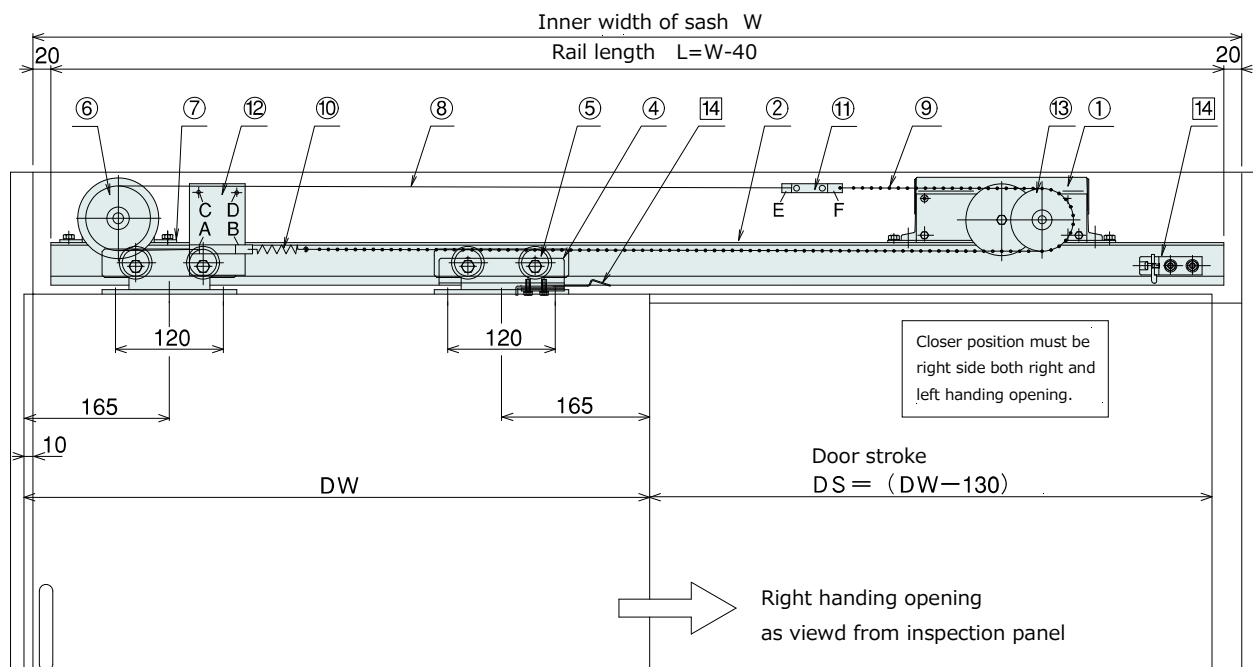
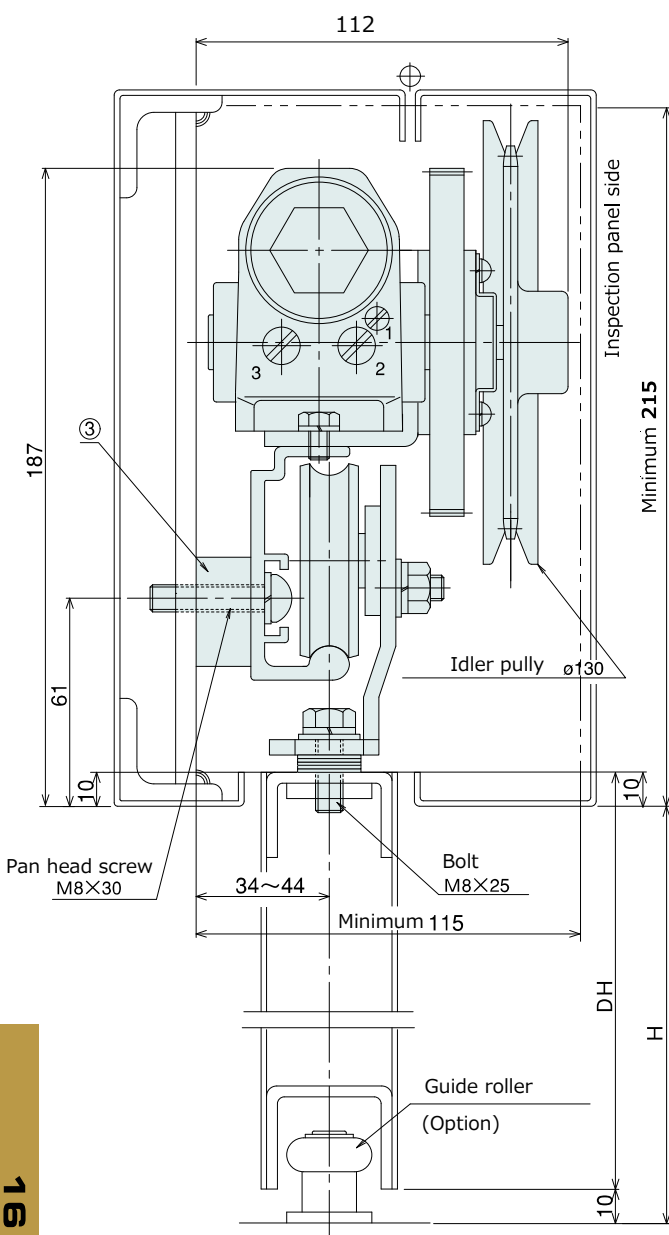

①	Hydraulic closer assembly	Assy	1	With chain sprocket
②	Rail	Aluminum	1	
③	Rail mounting piece	Plastic	(13)	Door height adjustable
④	Door hanger	SS400	2	With ball bearing
⑤	Hanger roller	Plastic	4	With ball bearing
⑥	Idler pulley	Plastic	1	
⑦	Pully bracket	SS400	1	
⑧	Wire (3mm)	Stainless	1	
⑨	Roller chain	JIS RS-25	1	
⑩	Chain spring	SWPB	1	
⑪	Wire chain connector	SS400	2	
⑫	Wire chain bracket	SS400	1	
⑬	Chain sprocket	SS400	1	
⑭	Hold open device	Assy	1	Option

This diagrams shows right-hand opening.
 To change left-hand opening,
 1.) Take out screw "A" & "B" of wire-chain bracket (⑫).
 2.) Close door at right side.
 3.) Wire chain connector(⑪) "E" & "F" connect to "C" & "D" of wire chain bracket(⑫)

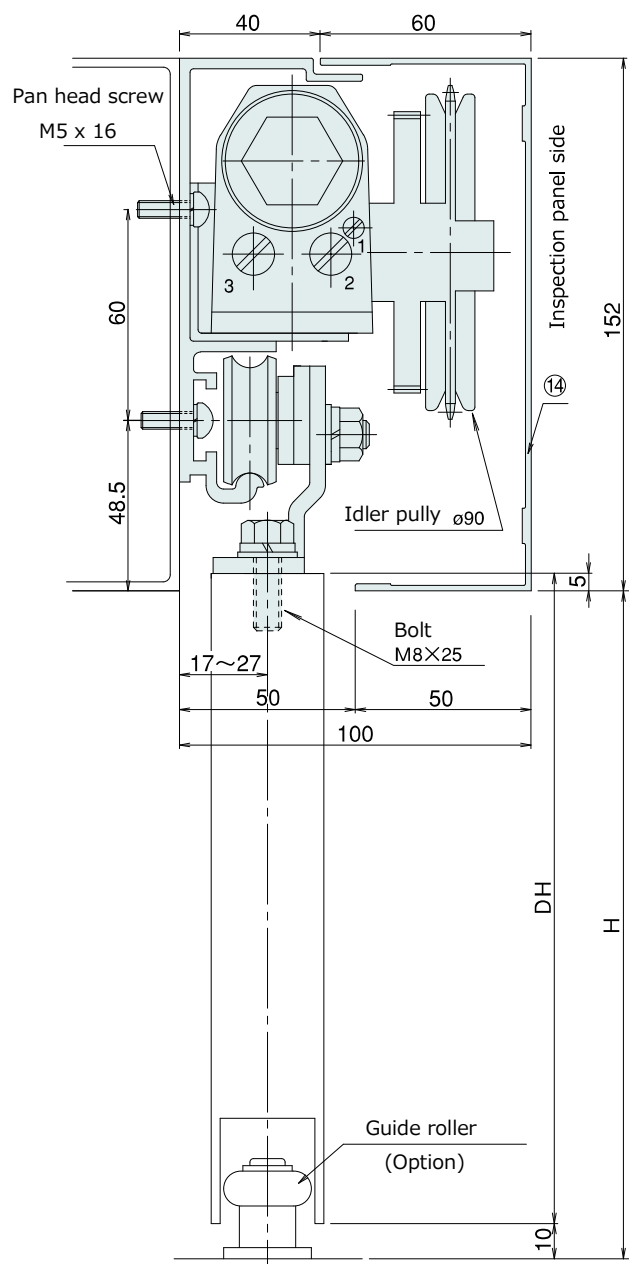

No.	Parts name	Material	Q'ty	Remark	No.	Parts name	Material	Q'ty	Remark
①	Hydraulic closer assembly	Assy	1	With chain sprocket	⑨	Wire chain connector	SS400	2	
②	Rail	Alm.	1		⑩	Wire chain bracket	SS400	1	
③	Door hanger	SS400	2		⑪	Chain sprocket	SS400	1	
④	Hanger roller	Plastic	4	With ball bearing	⑫	Door stopper	Assy	2	
⑤	Idler pulley	Plastic	1	With ball bearing	⑬	Side cover	Alum.	2	3.5mm
⑥	Pully bracket	SS400	1		⑭	Cover	Alum.	1	
⑦	Roller chain	JIS RS-25	1		⑮	Hold open device	Assy	1	Option
⑧	Chain spring	SWPB	1						

□ Option

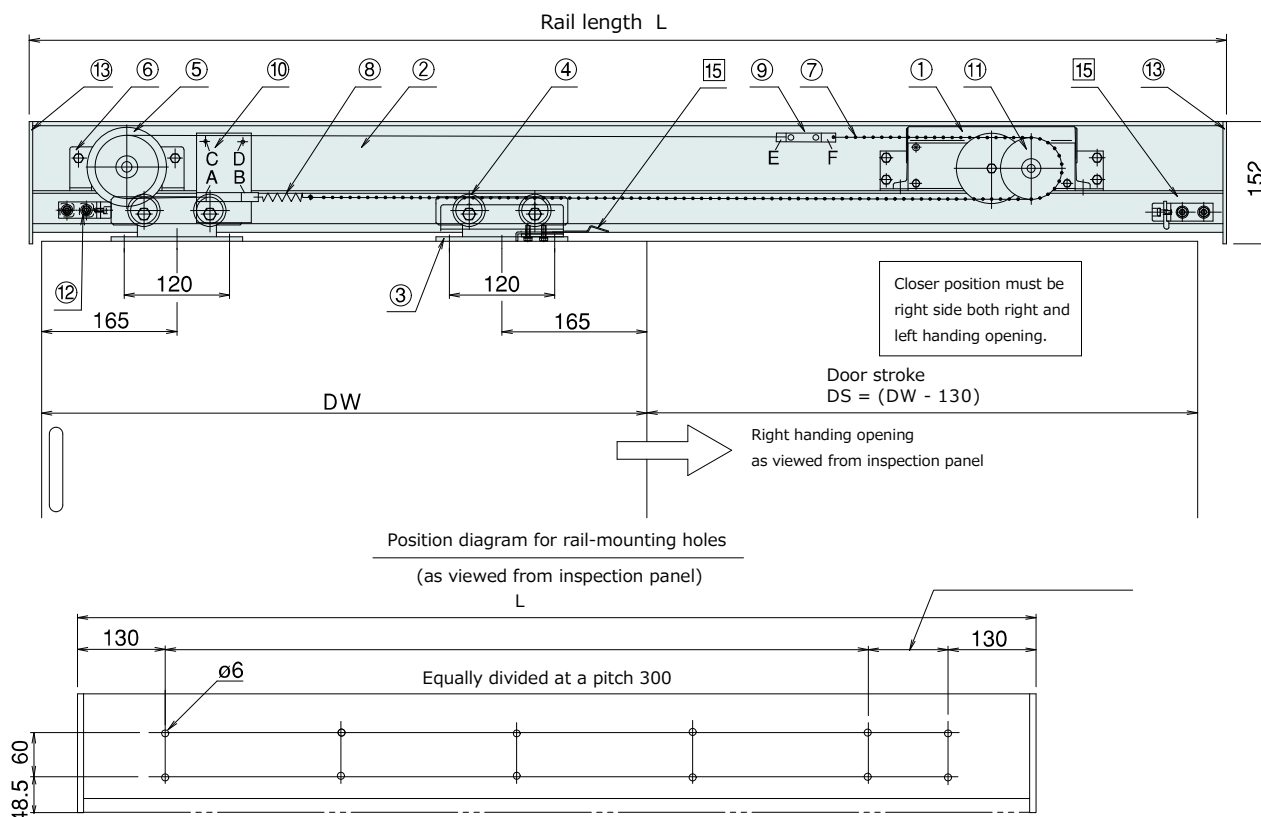

* This diagrams shows right-hand opening.

To change left-hand opening,

- 1.) Take out screw "A" & "B" of wire-chain bracket (⑩).
- 2.) Close the door at right side.
- 3.) Wire chain connector(⑨) "E" & "F" connect to "C" & "D" of wire chain bracket(⑩)

* Aluminum cover (silver & bronze color) is available.

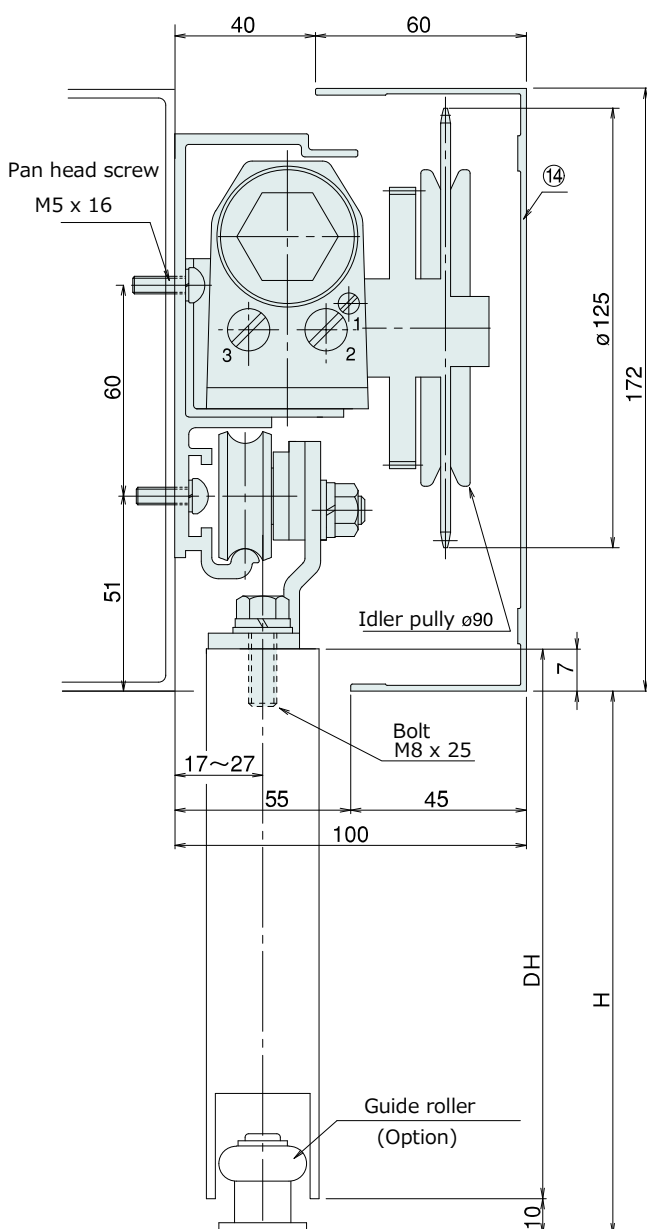

No.	Parts name	Material	Q'ty	Remark	No.	Parts name	Material	Q'ty	Remark
①	Hydraulic closer assembly	Assy	1	With chain sprocket	⑨	Wire chain connector	SS400	2	
②	Rail	Alm.	1		⑩	Wire chain bracket	SS400	1	
③	Door hanger	SS400	2		⑪	Chain sprocket	SS400	1	
④	Hanger roller	Plastic	4	With ball bearing	⑫	Door stopper	Assy	2	
⑤	Idler pulley	Plastic	1	With ball bearing	⑬	Side cover	Alum.	2	3.5mm
⑥	Pully bracket	SS400	1		⑭	Cover	Alum.	1	
⑦	Roller chain	JIS RS-25	1		⑮	Hold open device	Assy	1	Option
⑧	Chain spring	SWPB	1						

□ Option

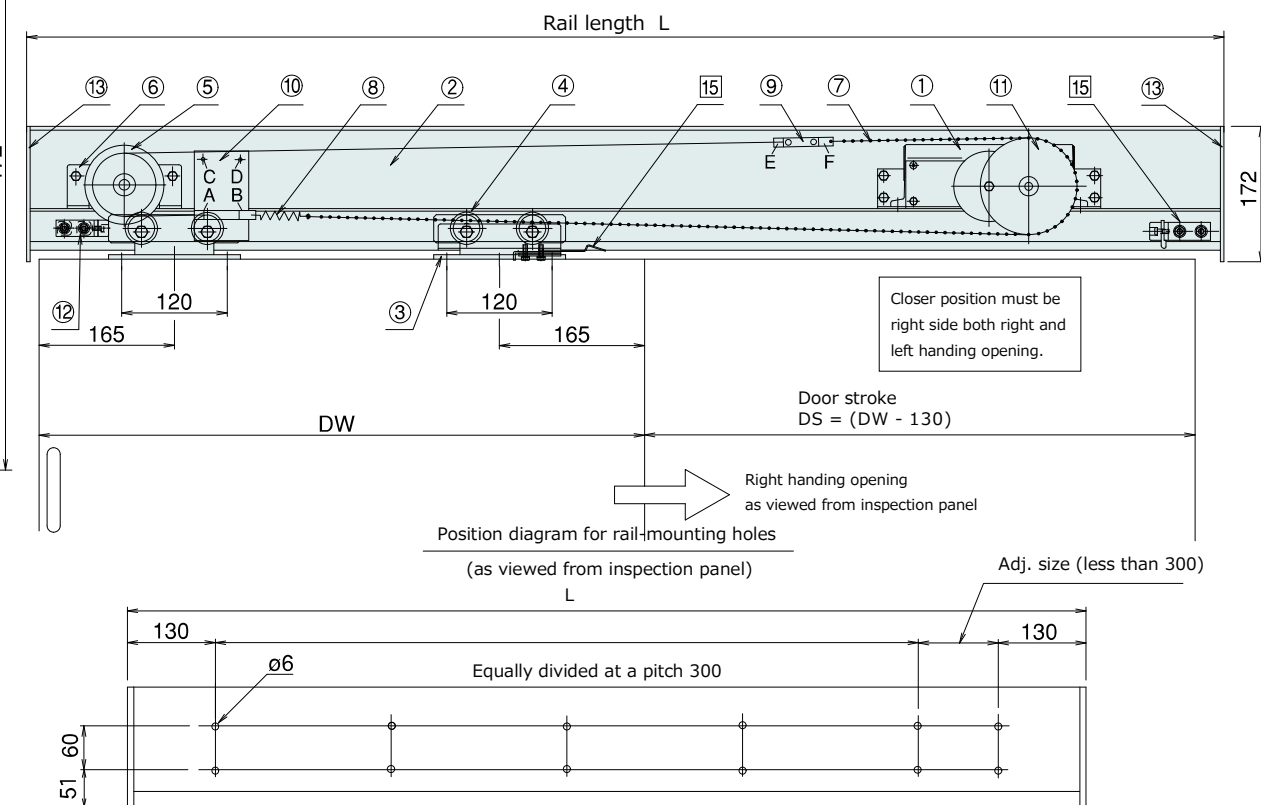

* This diagrams shows right-hand opening.

To change left-hand opening,

- 1.) Take out screw "A" & "B" of wire-chain bracket (⑩).
- 2.) Close the door at right side.
- 3.) Wire chain connector(⑨) "E" & "F" connect to "C" & "D" of wire chain bracket(⑩)

* Aluminum cover (silver & bronze color) is available.